

UNITED STATES
SECURITIES AND EXCHANGE COMMISSION
Washington, D.C. 20549

Form 10-Q

(Mark One)

QUARTERLY REPORT PURSUANT TO SECTION 13 OR 15(d) OF THE SECURITIES EXCHANGE ACT OF 1934

For the quarterly period ended **September 30, 2018**

or

TRANSITION REPORT UNDER SECTION 13 OR 15(d) OF THE SECURITIES EXCHANGE ACT OF 1934

For the transition period from _____ to _____

Commission File Number **000-54756**

PACIFIC GREEN TECHNOLOGIES INC.

(Exact name of registrant as specified in its charter)

Delaware

(State or other jurisdiction of
incorporation or organization)

5205 Prospect Road, Suite 135-226, San Jose, CA

(Address of principal executive offices)

N/A

(IRS Employer
Identification No.)

95129

(Zip Code)

(408) 538-3373

(Registrant's telephone number, including area code)

N/A

(Former name, former address and former fiscal year, if changed since last report)

Indicate by check mark whether the registrant (1) has filed all reports required to be filed by Section 13 or 15(d) of the Securities Exchange Act of 1934 during the preceding 12 months (or for such shorter period that the registrant was required to file such reports), and (2) has been subject to such filing requirements for the past 90 days. YES NO

Indicate by check mark whether the registrant has submitted electronically and posted on its corporate Web site, if any, every Interactive Data File required to be submitted and posted pursuant to Rule 405 of Regulation S-T (§232.405 of this chapter) during the preceding 12 months (or for such shorter period that the registrant was required to submit and post such files). YES NO

Indicate by check mark whether the registrant is a large accelerated filer, an accelerated filer, a non-accelerated filer, smaller reporting company, or an emerging growth company. See the definitions of "large accelerated filer," "accelerated filer," "smaller reporting company," and "emerging growth company" in Rule 12b-2 of the Exchange Act.

Large accelerated filer	<input type="checkbox"/>	Accelerated filer	<input type="checkbox"/>
Non-accelerated filer	<input type="checkbox"/> (Do not check if a smaller reporting company)	Smaller reporting company	<input checked="" type="checkbox"/>
		Emerging growth company	<input type="checkbox"/>

If an emerging growth company, indicate by check mark if the registrant has elected not to use the extended transition period for complying with any new or revised financial accounting standards provided pursuant to Section 13(a) of the Exchange Act.

Indicate by check mark whether the registrant is a shell company (as defined in Rule 12b-2 of the Exchange Act) YES NO

APPLICABLE ONLY TO ISSUERS INVOLVED IN BANKRUPTCY
PROCEEDINGS DURING THE PRECEDING FIVE YEARS

Check whether the registrant has filed all documents and reports required to be filed by Sections 12, 13 or 15(d) of the Exchange Act after the distribution of securities under a plan confirmed by a court. YES NO

APPLICABLE ONLY TO CORPORATE ISSUERS

Indicate the number of shares outstanding of each of the issuer's classes of common stock, as of the latest practicable date.

43,503,923 common shares issued and outstanding as of November 16, 2018.

TABLE OF CONTENTS

PART I – FINANCIAL INFORMATION	1
ITEM 1. FINANCIAL STATEMENTS	1
ITEM 2. MANAGEMENT’S DISCUSSION AND ANALYSIS OF FINANCIAL CONDITION AND RESULTS OF OPERATIONS	3
ITEM 3. QUANTITATIVE AND QUALITATIVE DISCLOSURES ABOUT MARKET RISK	18
ITEM 4. CONTROLS AND PROCEDURES	18
PART II – OTHER INFORMATION	20
ITEM 1. LEGAL PROCEEDINGS	20
ITEM 1A. RISK FACTORS	20
ITEM 2. UNREGISTERED SALES OF EQUITY SECURITIES	20
ITEM 3. DEFAULTS UPON SENIOR SECURITIES	20
ITEM 4. MINE SAFETY DISCLOSURES	20
ITEM 5. OTHER INFORMATION	20
ITEM 6. EXHIBITS	20

PART I – FINANCIAL INFORMATION

Item 1. Financial Statements

Our unaudited interim consolidated financial statements for the six month period ended September 30, 2018 form part of this quarterly report. They are stated in United States Dollars (US\$) and are prepared in accordance with United States generally accepted accounting principles for interim financial information and with the instructions to Form 10-Q and Article 8 of Regulation S-X.

PACIFIC GREEN TECHNOLOGIES INC.
Condensed Consolidated Financial Statements
September 30, 2018
(Expressed in US dollars)
(unaudited)

	<u>Index</u>
Condensed Consolidated Balance Sheets	F-1
Condensed Consolidated Statements of Operations and Comprehensive Loss	F-2
Condensed Consolidated Statements of Cash Flows	F-3
Notes to the Condensed Consolidated Financial Statements	F-4

PACIFIC GREEN TECHNOLOGIES INC.

Condensed Consolidated Balance Sheets

(Expressed in U.S. dollars)

	September 30, 2018 \$	March 31, 2018 \$
	(unaudited)	
ASSETS		
Cash	875,968	229,882
Amounts receivable	11,014	4,912
Prepaid expenses and deposits (Note 9)	978,562	72,032
Due from related parties (Note 8)	25,095	25,101
Total Current Assets	1,890,639	331,927
Lease receivable (Note 3)	1,995,000	1,995,000
Property and equipment (Note 4)	11,088	15,800
Intangible assets (Note 5)	10,184,161	10,622,068
Total Assets	14,080,888	12,964,795
LIABILITIES AND STOCKHOLDERS' EQUITY		
Current Liabilities		
Accounts payable and accrued liabilities	765,756	888,760
Convertible debenture (Note 6)	30,000	30,000
Due to related parties (Note 8)	79,224	229,544
Derivative liability (Note 7)	256,371	75,505
Total Liabilities	1,131,351	1,223,809
Nature of Operations and Continuance of Business (Note 1)		
Commitments (Note 13)		
Subsequent Events (Note 14)		
Stockholders' Equity		
Preferred stock, 10,000,000 shares authorized, \$0.001 par value Nil shares issued and outstanding	–	–
Common stock, 500,000,000 shares authorized, \$0.001 par value 43,403,923 and 40,757,415 shares issued and outstanding, respectively	43,404	40,757
Common stock issuable (Note 9)	–	206,675
Additional paid-in capital	83,097,123	78,989,346
Accumulated other comprehensive income	152,135	268,259
Deficit	(70,343,125)	(67,764,051)
Total Stockholders' Equity	12,949,537	11,740,986
Total Liabilities and Stockholders' Equity	14,080,888	12,964,795

(The accompanying notes are an integral part of these condensed consolidated financial statements)

PACIFIC GREEN TECHNOLOGIES INC.

Condensed Consolidated Statements of Operations and Comprehensive Loss

(Expressed in U.S. dollars)

(unaudited)

	Three Months Ended September 30, 2018 \$	Three Months Ended September 30, 2017 \$	Six Months Ended September 30, 2018 \$	Six Months Ended September 30, 2017 \$
Expenses				
Advertising and promotion	69,425	8,100	103,942	23,950
Amortization of intangible assets (Note 5)	218,954	218,953	437,907	437,906
Consulting fees (Note 8)	830,887	76,996	1,187,971	178,799
Depreciation (Note 4)	2,356	2,357	4,712	4,713
Foreign exchange loss (gain)	(20,845)	(50,556)	(165,574)	47,915
Office and miscellaneous	17,653	16,866	80,296	63,697
Professional fees	88,405	49,760	157,947	89,289
Research and development	–	377,660	–	429,964
Salaries and wages	171,364	–	171,364	–
Stock-based compensation (Note 11)	174,249	–	174,249	–
Transfer agent and filing fees	10,359	12,550	27,381	25,851
Travel	128,494	75,919	211,988	126,338
Total expenses	1,691,301	788,605	2,392,183	1,428,422
Loss before other income (expenses)	(1,691,301)	(788,605)	(2,392,183)	(1,428,422)
Other income (expenses)				
Gain on extinguishment of debt	–	97,631	–	97,631
Loss on change in fair value of derivative liability (Note 7)	(35,719)	(179,309)	(180,866)	(284,369)
Impairment of property and equipment	–	(290,580)	–	(290,580)
Interest expense (Notes 6 and 7)	(3,035)	(75,296)	(6,025)	(343,999)
Total other income (expense)	(38,754)	(447,554)	(186,891)	(821,317)
Net loss for the period	(1,730,055)	(1,236,159)	(2,579,074)	(2,249,739)
Other comprehensive income (loss)				
Foreign currency translation gain (loss)	(1,894)	(1,946)	(116,124)	42,104
Comprehensive loss for the period	(1,731,949)	(1,238,105)	(2,695,198)	(2,207,635)
Net loss per share, basic and diluted	(0.04)	(0.04)	(0.06)	(0.08)
Weighted average number of shares outstanding	43,234,278	27,585,317	42,454,659	27,378,218

(The accompanying notes are an integral part of these condensed consolidated financial statements)

PACIFIC GREEN TECHNOLOGIES INC.
Condensed Consolidated Statements of Cash Flows
(Expressed in U.S. dollars)
(unaudited)

	Six Months Ended September 30, 2018 \$	Six Months Ended September 30, 2017 \$
Operating Activities		
Net loss for the period	(2,579,074)	(2,249,739)
Adjustments to reconcile net loss to net cash used in operating activities:		
Accretion of discounts on note payable and convertible debenture	–	33,348
Amortization of intangible assets	437,907	437,906
Impairment of property and equipment	–	290,580
Imputed interest	–	306,662
Depreciation	4,712	4,713
Gain on extinguishment of debt	–	(97,631)
Loss on change in fair value of derivative liability	180,866	284,369
Stock-based compensation	174,249	9,900
Stock issued for services	793,000	–
Changes in operating assets and liabilities:		
Amounts receivable	(6,102)	20,613
Prepaid expenses	(906,530)	(60,013)
Due from related parties	6	(201)
Accounts payable and accrued liabilities	(123,004)	215,521
Due to related parties	(149,820)	10,000
Net Cash Used In Operating Activities	(2,173,790)	(793,972)
Investing Activities		
Purchase of property and equipment	–	(669,466)
Net Cash Used In Investing Activities	–	(669,466)
Financing Activities		
Proceeds from issuance of common stock	2,936,000	1,470,000
Repayments to related parties	–	(222,450)
Repayment of loan payable	–	(56,666)
Net Cash Provided by Financing Activities	2,936,000	1,190,884
Effect of Foreign Exchange Rate Changes on Cash	(116,124)	40,800
Change in Cash	646,086	(231,754)
Cash, Beginning of Period	229,882	382,167
Cash, End of Period	875,968	150,413
Non-cash Investing and Financing Activities:		
Accrued interest settled with common stock	–	85,483
Amount due to related parties settled with common stock	500	3,636,595
Amount due to related parties settled with stock options	–	78,165
Convertible debenture settled with common stock	–	20,000
Derivative liability settled with common stock	–	107,545
Loan payable settled with common stock	–	319,418
Note payable settled with common stock	–	5,000,000
Stock issued for services included in prepaid expenses	251,537	–
Supplemental Disclosures:		
Interest paid	–	–
Income taxes paid	–	–

(The accompanying notes are an integral part of these condensed consolidated financial statements)

PACIFIC GREEN TECHNOLOGIES INC.

Notes to the Condensed Consolidated Financial Statements
September 30, 2018
(Expressed in U.S. Dollars)
(unaudited)

1. Nature of Operations and Continuance of Business

Pacific Green Technologies Inc. (the “Company”) was incorporated in the state of Delaware on March 10, 1994, under the name of Beta Acquisition Corp. In September 1995, the Company changed its name to In-Sports International, Inc. In August 2002, the Company changed its name to ECash, Inc. On June 13, 2012, the Company changed its name to Pacific Green Technologies Inc. The Company is in the business of acquiring, developing, and marketing emission control technologies.

The accompanying condensed consolidated financial statements of the Company should be read in conjunction with the consolidated financial statements and accompanying notes filed with the U.S. Securities and Exchange Commission in the Company’s Annual Report on Form 10-K for the fiscal year ended March 31, 2018. In the opinion of management, the accompanying condensed consolidated financial statements reflect all adjustments of a recurring nature considered necessary to present fairly the Company’s financial position and the results of its operations and its cash flows for the periods shown.

The preparation of these condensed consolidated financial statements in accordance with accounting principles generally accepted in the United States requires management to make estimates and assumptions that affect the amounts reported. Actual results could differ materially from those estimates. The results of operations and cash flows for the periods shown are not necessarily indicative of the results to be expected for the full year.

These condensed consolidated financial statements have been prepared on a going concern basis, which implies the Company will continue to realize its assets and discharge its liabilities in the normal course of business. The continuation of the Company as a going concern is dependent upon the continued financial support from its shareholders, creditors, and related parties, and the ability of the Company to generate profitable operations. As at September 30, 2018, the Company has begun commercial sales generating revenues; the Company has an accumulated deficit of \$70,343,125 since inception. A history of significant losses raises doubts regarding the Company’s ability to continue as a going concern. These consolidated financial statements do not include any adjustments to the recoverability and classification of recorded asset amounts and classification of liabilities that might be necessary should the Company be unable to continue as a going concern.

2. Significant Accounting Policies

(a) Basis of Presentation

These condensed consolidated financial statements and related notes are presented in accordance with accounting principles generally accepted in the United States, and are expressed in U.S. dollars. These condensed consolidated financial statements include the accounts of the Company and the following active entities:

Pacific Green Marine Technologies Ltd. (“PGMTL”)	Wholly-owned subsidiary
Pacific Green Marine Technologies Inc. (“PGMTI”)	Wholly-owned subsidiary
Pacific Green Technologies International Limited (“PGTIL”)	Wholly-owned subsidiary
PGT Technologies (Canada) Ltd (“PGT CAN”)	Wholly-owned subsidiary
Pacific Green Technologies Asia Limited (“PGTA”)	Wholly-owned subsidiary of PGTIL
Pacific Green Technologies China Limited (“PGTC”)	Wholly-owned subsidiary of PGTA

All inter-company balances and transactions have been eliminated.

(b) Financial Instruments and Fair Value Measurements

ASC 820, “Fair Value Measurements and Disclosures” requires an entity to maximize the use of observable inputs and minimize the use of unobservable inputs when measuring fair value. ASC 820 establishes a fair value hierarchy based on the level of independent, objective evidence surrounding the inputs used to measure fair value. A financial instrument’s categorization within the fair value hierarchy is based upon the lowest level of input that is significant to the fair value measurement. ASC 820 prioritizes the inputs into three levels that may be used to measure fair value:

Level 1

Level 1 applies to assets or liabilities for which there are quoted prices in active markets for identical assets or liabilities.

Level 2

Level 2 applies to assets or liabilities for which there are inputs other than quoted prices that are observable for the asset or liability such as quoted prices for similar assets or liabilities in active markets; quoted prices for identical assets or liabilities in markets with insufficient volume or infrequent transactions (less active markets); or model-derived valuations in which significant inputs are observable or can be derived principally from, or corroborated by, observable market data.

PACIFIC GREEN TECHNOLOGIES INC.

Notes to the Condensed Consolidated Financial Statements
September 30, 2018
(Expressed in U.S. Dollars)
(unaudited)

2. Significant Accounting Policies (continued)

(b) Financial Instruments and Fair Value Measurements (continued)

Level 3

Level 3 applies to assets or liabilities for which there are unobservable inputs to the valuation methodology that are significant to the measurement of the fair value of the assets or liabilities.

The Company's financial instruments consist principally of cash, amounts receivable, lease receivable, amounts due from and to related parties, accounts payable and accrued liabilities, convertible debenture, and derivative liability. The recorded values of these financial instruments approximate their current fair values because of their nature and respective maturity dates or durations.

The following table represents assets and liabilities that are measured and recognized at fair value as of September 30, 2018, on a recurring basis:

	Level 1	Level 2	Level 3
	\$	\$	\$
Cash	875,968	–	–
Derivative liability	–	256,371	–
Total	875,968	256,371	–

During the six months ended September 30, 2018, the Company recognized a loss on the change in fair value of derivative liability of \$180,866 (2017 – \$284,369).

(c) Recent Accounting Pronouncements

In February 2016, the FASB issued new lease accounting guidance in ASU No. 2016-02, "Leases". This new guidance was initiated as a joint project with the International Accounting Standards Board to simplify lease accounting and improve the quality of and comparability of financial information for users. This new guidance would eliminate the concept of off-balance sheet treatment for "operating leases" for lessees for the vast majority of lease contracts. Under ASU No. 2016-02, at inception, a lessee must classify all leases with a term of over one year as either finance or operating, with both classifications resulting in the recognition of a defined "right-of-use" asset and a lease liability on the balance sheet. However, recognition in the income statement will differ depending on the lease classification, with finance leases recognizing the amortization of the right-of-use asset separate from the interest on the lease liability and operating leases recognizing a single total lease expense. Lessor accounting under ASU No. 2016-02 would be substantially unchanged from the previous lease requirements under GAAP. ASU No. 2016-02 will take effect for public companies in fiscal years beginning after December 15, 2018, including interim periods within those fiscal years. Early adoption is permitted and for leases existing at, or entered into after, the beginning of the earliest comparative period presented in the financial statements, lessees and lessors must apply a modified retrospective transition approach. The Company is currently evaluating the new guidance and has not determined the impact this standard may have on the consolidated financial statements.

The Company has implemented all new accounting pronouncements that are in effect and that may impact its consolidated financial statements and does not believe that there are any other new accounting pronouncements that have been issued that might have a material impact on its financial position or results of operations.

3. Lease Receivable

In December 2017, the Company completed the installation and the accounting sale of a constructed scrubber system. The Company's investment in sales-type lease as at March 31, 2018, consists of an amount due from the customer under a long-term lease arrangement. No amount has been allocated to residual value or other deliverables; accordingly, the amount presented in the balance sheet represents the present value of amounts due under the energy management contract. The entire amount is presented as a long-term receivable.

PACIFIC GREEN TECHNOLOGIES INC.

Notes to the Condensed Consolidated Financial Statements

September 30, 2018

(Expressed in U.S. Dollars)

(unaudited)

4. Property and Equipment

	Cost \$	Accumulated amortization \$	September 30, 2018 Net carrying value \$	March 31, 2018 Net carrying value \$
Furniture and equipment	4,155	1,662	2,493	2,908
Leasehold improvements	25,784	17,189	8,595	12,892
	29,939	18,851	11,088	15,800

5. Intangible Assets

	Cost \$	Accumulated amortization \$	Impairment \$	September 30, 2018 Net carrying value \$	March 31, 2018 Net carrying value \$
Patents and technical information	35,852,555	(5,211,139)	(20,457,255)	10,184,161	10,622,068

On May 17, 2013, the Company entered into an Assignment of Assets agreement with EnviroTechnologies, Inc. (“Enviro”), a non-related party, whereby the Company acquired various patents and technical information related to the manufacture of a wet scrubber for removing sulphur, other pollutants, and the particulate matter from diesel engine exhaust. In exchange for these assets, the Company waived all obligations owing to the Company as well as agreed to return a total of 88,876,443 of Enviro’s shares back to Enviro. The obligations waived consisted of \$237,156 owing to the Company as well as \$93,721 of debt owing to Pacific Green Group Limited (“PGG”), a company controlled by a shareholder of the Company who has a significant influence on the Company’s operations, which was assigned to the Company. The Company entered into share exchange agreements with Enviro shareholders pursuant to which it issued shares of its common stock in exchange for shares of Enviro on a one-for-ten basis. The intangible assets acquired were recorded at cost and is being amortized using the straight-line method over the estimated useful life of 17 years.

6. Convertible Debenture

On November 10, 2015, the Company entered into a \$110,000 convertible debenture with a non-related party, in exchange for \$100,000, net of \$10,000 for legal fees which was deferred and amortized over the term of the debenture. Under the terms of the debenture, the amount is unsecured, bears guaranteed interest at 10% and default interest at 20% per annum, and was due on November 10, 2016. The note is convertible into shares of common stock of the Company equal to the lower of: (a) \$0.40 or (b) 60% of the lowest trading price of the Company’s common stock during the 20 consecutive trading days prior to the date of conversion. In the event of a default, the discount shall be permanently increased by 10%.

The Company analyzed the conversion option under ASC 815, and determined that the conversion feature should be classified as a liability and recorded at fair value due to there being no explicit limit to the number of shares to be delivered upon settlement of the conversion option. In accordance with ASC 815, the Company recognized the intrinsic value of the embedded beneficial conversion feature of \$110,000. On February 22, 2017, the Company issued 50,000 shares of common stock for the conversion of \$20,000 of this debenture. On August 10, 2017, the Company issued 100,000 shares of common stock for the conversion of \$20,000 of this debenture. On October 4, 2017, the Company issued 320,000 shares of common stock for the conversion of \$40,000 of this debenture. As at September 30, 2018, the carrying value of the debenture was \$30,000 (March 31, 2018 - \$30,000) and the fair value of the derivative liability was \$256,371 (March 31, 2018 - \$75,505).

7. Derivative Liability

The Company records the fair value of the conversion price of the convertible debenture disclosed in Note 6 in accordance with ASC 815. The fair value of the derivative liability was calculated using a binomial option pricing model. The fair value of the derivative liability is revalued on each balance sheet date with corresponding gains and losses recorded in the consolidated statement of operations. During the six months ended September 30, 2018, the Company recorded a loss on the change in fair value of derivative liability of \$180,866 (2017 – \$284,368). As at September 30, 2018, the Company recorded derivative liability of \$256,371 (March 31, 2018 - \$75,505).

PACIFIC GREEN TECHNOLOGIES INC.

Notes to the Condensed Consolidated Financial Statements

September 30, 2018

(Expressed in U.S. Dollars)

(unaudited)

7. Derivative Liability (continued)

The following inputs and assumptions were used to calculate the fair value of the beneficial conversion feature of the convertible debenture outstanding as at September 30, 2018, assuming no expected dividends:

	As at September 30, 2018
Estimated common stock issuable upon conversion	170,797
Estimated exercise price per common share	0.40
Risk-free interest rate	2.19%
Expected volatility	87%
Expected life (in years)	0.25

A summary of the activity of the derivative liability is shown below:

	\$
Balance, March 31, 2018	75,505
Mark to market adjustment	180,866
Balance, September 30, 2018	256,371

8. Related Party Transactions

- (a) As at September 30, 2018, the Company was owed \$25,095 (March 31, 2018 - \$25,101) from a shareholder of the Company who has a significant influence on the Company's operations. The amount owed is unsecured, non-interest bearing, and due on demand.
- (b) As at September 30, 2018, the Company owed \$19,737 (March 31, 2018 - \$198,175) to PGG, a company controlled by a shareholder of the Company who has a significant influence on the Company's operations, of which \$nil (March 31, 2018 - \$28,618) was recorded in accounts payable and accrued liabilities. The amounts owing are unsecured, non-interest bearing, and due on demand.
- (c) As at September 30, 2018, the Company owed \$71,235 (March 31, 2018 - \$64,195) to directors of the Company, of which \$11,748 (March 31, 2018 - \$4,208) was recorded in accounts payable and accrued liabilities. The amounts owing are unsecured, non-interest bearing, and due on demand.
- (d) During the six months ended September 30, 2018, the Company incurred \$125,000 (2017 - \$120,000) in consulting fees to PGG, a company controlled by a shareholder of the Company who has a significant influence on the Company's operations.
- (e) During the six months ended September 30, 2018, the Company incurred \$120,000 (2017 - \$20,000) in consulting fees to a company controlled by a director of the Company.

9. Common Stock

- (a) On April 28, 2018, the Company issued 206,675 shares of common stock relating to a non-brokered private placement at a price of \$1.00 per share for proceeds of \$206,675, which was recorded as common stock issuable as at March 31, 2018.
- (b) On May 28, 2018, the Company entered into securities purchase agreements ("SPA's") with seven investors. The SPA's include subscription agreements for 1,957,333 shares of common stock at a price of \$1.50 per share for proceeds of \$2,936,000, and 1,957,333 share purchase warrants exercisable at a price of \$2.50 per share expiring on July 1, 2020. The SPA's included conditional subscription agreements for the purchase of an additional 1,342,665 shares of common stock and 1,342,665 share purchase warrants exercisable at \$2.50 per share expiring on July 1, 2020. Upon the Company meeting a specified sales target by December 31, 2018, the conditional subscriptions will be completed at \$1.50 per unit on or before January 10, 2019. If the Company fails to achieve the specified sales target, then the investors have the option to complete the conditional subscription agreements for the purchase of an additional 1,853,998 shares of common stock and 1,853,998 share purchase warrants exercisable at \$2.00 per share expiring on July 1, 2020 for \$2.00 per unit on or before January 15, 2019.

PACIFIC GREEN TECHNOLOGIES INC.

Notes to the Condensed Consolidated Financial Statements

September 30, 2018

(Expressed in U.S. Dollars)

(unaudited)

9. Common Stock (continued)

- (c) On June 12, 2018, the Company issued 287,500 shares of common stock with a fair value of \$517,500 to three consultants for consulting services. As at September 30, 2018, \$67,869 of the value of the shares remains in prepaid expenses to be recognized over the remaining term of service.
- (d) On July 5, 2018, the Company issued 50,000 shares of common stock for the settlement of \$500 owed to a director of the Company pursuant to the exercise of stock options.
- (e) On September 28, 2018, the Company issued 145,000 shares of common stock with a fair value of \$275,000 to seven consultants for consulting services. As at September 30, 2018, \$183,668 of the value of the shares remains in prepaid expenses to be recognized over the remaining term of service.

10. Share Purchase Warrants

	Number of warrants	Weighted average exercise price \$
Balance, March 31, 2018	1,500,000	1.00
Issued	1,957,333	2.50
Balance, September 30, 2018	3,457,333	1.85

As at September 30, 2018, the following share purchase warrants were outstanding:

Number of warrants outstanding	Exercise price \$	Expiry date
500,000	1.00	November 23, 2018
1,000,000	1.00	November 23, 2019
1,957,333	2.50	July 1, 2020
3,457,333		

11. Stock Options

The following table summarizes the continuity of stock options issued and outstanding:

	Number of options	Weighted average exercise price \$	Aggregate intrinsic value \$
Balance, March 31, 2018	537,500	0.01	478,375
Granted	100,000	0.01	
Exercised	(50,000)	0.01	
Balance, September 30, 2018	587,500	0.01	1,110,375

PACIFIC GREEN TECHNOLOGIES INC.

Notes to the Condensed Consolidated Financial Statements

September 30, 2018

(Expressed in U.S. Dollars)

(unaudited)

11. Stock Options (continued)

Additional information regarding stock options outstanding as at September 30, 2018 is as follows:

Range of exercise prices \$	Outstanding and exercisable		
	Number of shares	Weighted average remaining contractual life (years)	Weighted average exercise price \$
0.01	587,500	0.9	0.01

On July 1, 2018, the Company granted 100,000 stock options to a consultant to the Company. The stock options are exercisable at \$0.01 per share for a period of two years. The options were recorded at their fair value of \$174,249 or \$1.74 per option at the time of grant.

On September 26, 2017, the Company granted 175,000 stock options to a company controlled by a director of the Company. The stock options are exercisable at \$0.01 per share for a two year term. These stock options were issued in exchange for management services previously accrued at \$175,000 and have been recorded at their fair value of \$78,165 as estimated using the Black-Scholes option pricing model assuming no expected dividends or forfeitures and the following weighted average assumptions:

The fair values were estimated using the Black-Scholes option pricing model assuming no expected dividends or forfeitures and the following assumptions:

	Six months ended September 30, 2018	Six months ended September 30, 2017
Risk-free interest rate	2.53%	1.45%
Expected life (in years)	2	2
Expected volatility	196%	251%

On July 17, 2018, the Company extended the life of 312,500 stock options previously granted to the Company's President and Chief Executive Officer. The expiry date of the stock options was extended from July 18, 2018 to April 30, 2019. The extension of the stock options did not result in any incremental compensation cost. The fair value was estimated using the Black-Scholes option pricing model assuming no expected dividends or forfeitures.

12. Segmented Information

The Company is located and operates in the United States and its subsidiaries are primarily located and operating in the United Kingdom and China.

	September 30, 2018			Total \$
	United States \$	United Kingdom \$	China \$	
Lease receivable	–	1,995,000	–	1,995,000
Property and equipment	11,088	–	–	11,088
Intangible assets	10,184,161	–	–	10,184,161
Total non-current assets	10,195,249	1,995,000	–	12,190,249

PACIFIC GREEN TECHNOLOGIES INC.

Notes to the Condensed Consolidated Financial Statements

September 30, 2018

(Expressed in U.S. Dollars)

(unaudited)

13. Commitments

- (a) On August 4, 2016, the Company entered into a three-year lease agreement commencing November 15, 2016. The minimum lease payments over the remaining term of the lease are as follows:

Fiscal Year	\$
2019	31,057
2020	39,339
	70,396

- (b) On January 1, 2017, PGTC entered into a one year tooling development agreement with a non-related party to begin tooling for pending projects in advance of orders to facilitate shorter delivery times. Pursuant to the agreement, PGTC will pay \$160,198 (RMB1,050,000), on the one year anniversary of the acceptance of the system.
- (c) On January 1, 2017, PGTC entered into a nine month sales and marketing agreement with a non-related party to conduct sales and marketing services for the scrubber system in China. Pursuant to the agreement, PGTC will pay \$160,198 (RMB1,050,000), on the nine month anniversary of the acceptance of the system.
- (d) On July 14, 2017, the Company entered into a new memorandum of understanding to establish a new joint venture company in China with a non-related party (the "Supplier") wherein the Supplier would receive and process orders, manufacture, and install products for the Company's customers. In return, the Company agreed to design the product, provide strategic pricing, sales and marketing direction, as well as provide technology licenses and technical support (the "Technology") to the Supplier. During the term of the agreement, the Company will provide the Supplier with a non-transferrable right and license to use the Technology to manufacture and install the product within the Asia and Russia region.

14. Subsequent Events

- (a) On October 10, 2018, the Company issued 100,000 shares of common stock for proceeds of \$1,000 pursuant to the exercise of stock options.
- (b) On November 1, 2018, the Company received proceeds of \$500,000 for 500,000 shares of common stock to be issued pursuant to the exercise of share purchase warrants.

Item 2. Management's Discussion and Analysis of Financial Condition and Results of Operations

FORWARD-LOOKING STATEMENTS

This quarterly report contains forward-looking statements. These statements relate to future events or our future financial performance. In some cases, you can identify forward-looking statements by terminology such as "could", "may", "will", "should", "expect", "plan", "anticipate", "believe", "estimate", "predict", "potential" or the negative of these terms or other comparable terminology. These statements are only predictions and involve known and unknown risks, uncertainties and other factors that may cause our or our industry's actual results, levels of activity, performance or achievements to be materially different from any future results, levels of activity, performance or achievements expressed or implied by these forward-looking statements.

Although we believe that the expectations reflected in the forward-looking statements are reasonable, we cannot guarantee future results, levels of activity, performance or achievements. Except as required by applicable laws, including the securities laws of the United States, we do not intend to update any of the forward-looking statements so as to conform these statements to actual results.

Our unaudited consolidated financial statements are stated in U.S. dollars and are prepared in accordance with generally accepted accounting principles in the United States. The following discussion should be read in conjunction with our financial statements and the related notes that appear elsewhere in this quarterly report.

As used in this current report and unless otherwise indicated, the terms "we", "us", "our" and "our company" mean Pacific Green Technologies Inc., a Delaware corporation, and our wholly owned subsidiaries, Pacific Green Marine Technologies Ltd, a United Kingdom corporation, Pacific Green Technologies International Limited, a British Virgin Islands corporation, and its wholly owned subsidiary, Energy Park Sutton Bridge, a United Kingdom corporation, PGT Technologies (Canada) Ltd, a Canadian corporation, Pacific Green Technologies Asia Limited, and its wholly owned subsidiary, Pacific Green Technologies China Limited, both Hong Kong companies.

Corporate History

Our company was incorporated in Delaware on March 10, 1994, under the name of Beta Acquisition Corp. In September 1995, we changed our name to In-Sports International, Inc. In August 2002, we changed our name from In-Sports International, Inc. to ECash, Inc. In 2007, due to limited financial resources, we discontinued our operations. Over the course of the last five years, we have sought new business opportunities.

On June 13, 2012, we changed our name to Pacific Green Technologies Inc. and effected a reverse split of our common stock following which we had 27,002 shares of common stock outstanding with \$0.001 par value.

Effective December 4, 2012, we filed with the Delaware Secretary of State a Certificate of Amendment of Certificate of Incorporation, wherein we increased our authorized share capital to 510,000,000 shares of stock as follows:

- 500,000,000 shares of common stock with a par value of \$0.001; and
- 10,000,000 shares of preferred stock with a par value of \$0.001.

The increase of authorized capital was approved by our board of directors on July 1, 2012 and by a majority of our stockholders by a resolution dated July 1, 2012.

Historical Business Overview

Details of other material contracts and commitments follows the New Strategy and Current business section.

New Strategy and Current business

Since 2012, the Company has focused on marketing, developing and acquiring technologies designed to improve the environment by reducing pollution. The Company has acquired technologies, patents and intellectual property from EnviroTechnologies Inc. through share transfer, assignment and representation agreements entered into during 2012 and 2013. Following those acquisitions, management has expanded the registration of intellectual property rights around the world and pursued opportunities globally for the development and marketing of the emission control technologies.

Working with a worldwide network of agents to market the ENVI-Systems™ emission control technologies, the Company has focused on three applications of the technology:

ENVI-Marine™

Diesel exhaust from ships, ferries and tankers includes ash and soot as particulate components and sulphur dioxide as an acid gas. Testing has been conducted on diesel shipping to confirm the application of seawater as a neutralizing agent for sulphur emissions as well as capturing particulate matter. In addition to marine applications, these tests also showed applicability of the system for large displacement engines such as stationary generators, compressors, container handling, heavy construction and mining equipment.

The Company manufactured the components for an ENVI-Marine unit that was installed in Union Maritimes' (Union) MV Westminster chemical ship during the summer of 2017. Under the terms of an Energy Management Lease dated December 16, 2016, Union will make quarterly payments to the Company determined on their savings realized by the ENVI-Marine units' operation up to an aggregate of \$1,995,000.

The Company has been actively marketing its ENVI-Marine™ units to ship brokers and ship owners.

ENVI-Pure™

Increasing legislation relating to landfill of municipal solid waste has led to the emergence of increasing numbers of waste to energy plants ("WtE"). A WtE plant obviates the need for landfill, burning municipal waste for conversion to electricity. A WtE plant is typically 45-100MW. The ENVI-Clean™ system is particularly suited to WtE as it cleans multiple pollutants in a single system.

ENVI-Clean™

EnviroTechnologies Inc. has successfully conducted sulphur dioxide demonstration tests at the American Bituminous Coal Partners power plant in Grant Town, West Virginia. The testing achieved a three test average of 99.3% removal efficiency. The implementation of US Clean Air regulations in July 2010 has created additional demand for sulphur dioxide removal in all industries emitting sulphur pollution. Furthermore, China consumes approximately one half of the world's coal, but introduced measures designed to reduce energy and carbon intensity in its 12th Five Year Plan. Applications include regional power facilities and heating for commercial buildings and greenhouses. Typical applications range in size from 1 to 20 megawatts (MW) with power generation occupying the larger end of the range.

Following the signing of a joint venture agreement with Power China SPEM, an ENVI-Clean™ was sold to a steelworks company in Yancheng to remove SO₂ from its 93MW gas combustion powerplant.

The ENVI-Clean™ system removes most of the sulphur dioxide, particulate matter, greenhouse gases and other hazardous air pollutants from the flue gases produced by the combustion of coal, biomass, municipal solid waste, diesel and other fuels.

The ENVI-Clean™ system is comprised of five components:

- an induced draft fan (“ID fan”);
- a gas conditioning chamber;
- the ENVI-Clean™ unit;
- a demister; and
- settling tanks.

The ID fan creates the pressure differential required to force the gas through the scrubbing fluid suspended on each head and move it through the other components in the system. The gas conditioning chamber cools the hot flue gas prior to entering the ENVI-Clean™ System. The ENVI-Clean™ System contains the heads and the demister pads at the exhaust exit. The neutralizing fluid is constantly circulated and cleaned by mechanical means with the contaminated component of the separation going to a settling tank prior to dewatering. The settled solids are disposed of with the bottom ash produced by the combustion process.

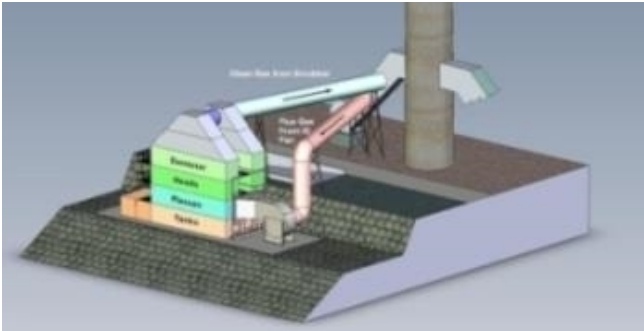

The ENVI-CES™ technology forces 100% of the polluted exhaust flue gas into the neutralizing fluid to produce a highly turbulent interaction between the target pollutants and the fluid. The aggressive mixing produces small bubbles which create a very high surface contact area between the exhaust gas and fluid to enhance the transfer of particulate and targeted gaseous and hazardous pollutants from the exhaust to the fluid.

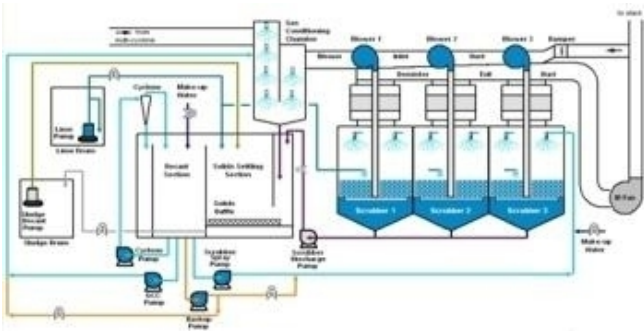

Schematic of the ENVI-Clean™ Emission's System as installed for Biomass applications

Unique to the ENVI approach is the introduction of the gas in the lower section of the ENVI-Clean™ unit which makes the greatest portion of its cross section available for fluid–gas interaction. This permits a smaller and highly flexible footprint. Furthermore, the system design allows for multiple heads each containing different neutralizing fluids to remove various pollutants from the flue gas. The ordered removal of acid and greenhouse gases within a single unit makes the system highly desirable by industries whose fuels contain multiple contaminants. The resulting ENVI-Clean™ unit has high efficiency and is very simple to operate.

The neutralizing solution is selected to remove targeted pollutants: limestone and hydrated lime are used to neutralize the scrubbing solution for the removal of acid gases such as sulphur dioxide, hydrogen chloride and hydrogen fluoride. The unique design of the ENVI system allows for the sequential removal of pollutants by stacking heads and utilizing different neutralizing chemistry in each operating unit. This provides industry with a system that fulfills multiple applications.

The ENVI-Clean™ system has numerous new and retrofit applications:

- coal and coal waste fuelled CFBC boilers;
- pulverized coal and stoker-grate boilers;
- heavy oil fired boilers;
- biomass and waste to energy boilers;
- lime kilns, dryers, shredders and foundries;
- industrial exhaust scrubbing of particulates and acid gases;
- diesel engines, large marine and stationary engines; and
- sewage sludge, hazardous waste and MSW incinerators.

Significant transactions

Management, assisted by PGG, identified an opportunity to build a business focused on marketing, developing and acquiring technologies designed to improve the environment by reducing pollution. To this end, we entered into and closed an assignment and share transfer agreement, on June 14, 2012, for the assignment of a representation agreement and the acquisition of a company involved in the environmental technology industry.

The assignment and share transfer agreement provided for the acquisition of 100% of the issued and outstanding shares of Pacific Green Technologies Limited, formerly PGG's subsidiary in the United Kingdom. Additionally, PGG has assigned to our company a ten year exclusive worldwide representation agreement with EnviroTechnologies Inc., (formerly EnviroResolutions, Inc.), a Delaware corporation, to market and sell EnviroTechnologies' current and future environmental technologies. The representation agreement entitles PGG to a commission of 20% of all sales (net of taxes) generated by EnviroTechnologies. Pursuant to the terms of the assignment and share transfer agreement, all rights and obligations under the representation agreement have been transferred to our company. We currently anticipate that sales under the representation agreement will be our sole source of revenue for the foreseeable future. We had intended to complete an acquisition of EnviroTechnologies, as this would have been a logical step in our development. However, as discussed herein, we have settled with EnviroTechnologies as an alternative.

Both Sichel and PGG are wholly owned subsidiaries of the Hookipa Trust. PGG's wholly owned subsidiary was Pacific Green Technologies Limited. As a result, we acquired Pacific Green Technologies Limited from PGG. Sichel is a significant shareholder of our company and also provides us with consulting services. The sole director of Sichel is also the sole director of PGG. Further, PGG is a significant shareholder of EnviroTechnologies.

The assignment and share transfer agreement closed on June 14, 2012 via the issuance of 5,000,000 shares of our common stock as well as a \$5,000,000 promissory note to PGG. We have consequently undertaken the operations of Pacific Green Technologies Limited and PGG's obligations under the representation agreement.

Full consideration contemplated by the assignment and share transfer agreement was \$25,000,000 satisfied through the issue of 5,000,000 new shares of our common stock at a price of \$4 per share with the balance of \$5,000,000 structured as a promissory note over the next five years as follows:

- June 12, 2013, \$1,000,000;
- June 12, 2014, \$1,000,000;
- June 12, 2015, \$1,000,000;
- June 12, 2016, \$1,000,000 and;
- June 12, 2017, \$1,000,000.

Under the terms of the promissory note, the loan repayments specified above shall not exceed the amount we earn under the terms of the representation agreement. If we are unable to meet the repayment schedule set out above, PGG will have the option to either roll over any unpaid portion to the following payment date or to convert the outstanding amount into new shares of our common stock. However, the entire amount of the promissory note is due upon the maturity date on the fifth anniversary. On September 25, 2017, the Company and PGG agreed to a settlement of the outstanding promissory by way of a subscription agreement for 5,000,000 shares of common stock at \$1.00 per share.

The initial total consideration of \$25,000,000 was a purchase price not determined under U.S. GAAP, and both the \$25,000,000 total price and the deemed price of \$4 per share does not represent the fair value of the stock issued or a value used in accounting for the acquisition. The number of shares issued and the terms of the promissory note were negotiated between the parties and are intended to represent full consideration for the acquisition of Pacific Green Technologies Limited and the representation agreement.

Our management believes that the ENVI-Clean™ system has significant competitive advantages in the market for emission control systems including:

1. *Efficiency*: tests performed at an 84MW coal power plant in West Virginia (USA) indicate that the ENVI-Clean™ system removed on average 99.3% of sulfur dioxide over a three day period from the plant's emissions;
2. *Low Capital Cost*: the system has a compact and flexible footprint relative to competitive products. For electricity generation applications, EnviroTechnologies' system is priced for market at approximately \$90 per kilowatt of electricity generation. In comparison, industry consultants state that comparable systems in North America are typically priced at \$300-500 per kilowatt (Source: High Energy Services/Babcock & Wilcox-wet scrubber systems for SO2 removal in North America);
3. *Low Ongoing Operating Cost*: the ENVI-Clean™ system is more affordable in the long term for customers compared to competitor products;
4. *New and Retrofit Applications*: for retrofit applications in particular (as required by the 2011 EPA Boiler MACT Requirements), the system is considered by management to be more compact and adaptable than rival systems;
5. *Scalability*: the ENVI-Clean™ system can be adapted for the largest power stations but also smaller applications such as diesel marine engines. It can also remove multiple pollutants in a single system, unlike much of the competition.

On October 5, 2011, EnviroResolutions, a British Columbia corporation, signed a contract to supply the ENVI-Clean™ system to a new waste to energy plant being built in Peterborough, United Kingdom (the "Peterborough Contract"). The initial material term and condition of the contract was that EnviroResolutions demonstrate testing of the system that achieved the performance levels represented in regards to emissions by March 31, 2012. This condition was successfully satisfied and confirmed with Peterborough Renewable Energy Limited ("PREL") prior to the required date. The Peterborough Contract entitles us, as the holder of the representation agreement, to a commission of approximately \$4,600,000 before third party agency fees.

Effective March 5, 2013, we entered into a supplemental agreement with EnviroTechnologies and EnviroResolutions. The supplemental agreement amends the representation agreement between PGG and EnviroTechnologies dated June 7, 2010, which was later assigned to us from PGG in connection with an assignment and share transfer agreement dated June 14, 2012. The supplemental agreement entitles our company to a commission of equal to 50% (previously 20%) of any licensing revenue that may be generated by EnviroTechnologies Inc. in respect of its existing and future technologies.

In addition, pursuant to the supplemental agreement, we will receive from EnviroResolutions an amount equal to 50% of any assets or consideration received as compensation from PREL for PREL's failure to perform under a contingent sale agreement dated October 5, 2011 between EnviroResolutions and PREL. We will receive the fee for our assistance to EnviroResolutions during their negotiations with PREL regarding PREL's failure to perform. The fee, if any, provided to us will not constitute any repayment of our loans that were made to EnviroResolutions.

The supplemental agreement supplements the Peterborough Contract dated October 5, 2011 entered into among EnviroResolutions, PREL and GEPL. Pursuant to the Peterborough Contract, EnviroResolutions was to supply PREL with a wet scrubbing emission control system to a proposed waste to energy plant being built in Peterborough, United Kingdom.

Information on Pacific Green Technologies Limited

Pacific Green Technologies Limited is a limited liability company incorporated under the laws of England and Wales on April 5, 2011 (“PGT”). The director of PGT was Mr. Joseph Grigor Kelly. On November 7, 2012, Mr. Joseph Grigor Kelly tendered his resignation to the board of directors. PGT has no employees. Concurrently, Neil Carmichael consented to and was appointed as the sole director and chief executive and financial officer of PGT.

The purpose of incorporating PGT was to utilize local knowledge and contacts to build a platform for sales in the following regions: Western Europe, Eastern Europe, Russian Federation, Turkey, Middle East, Azerbaijan, Kazakhstan and Africa. However, our company has found that the cost to have physical presence in UK far out weights the benefit. As a result, PGT is now in the process of being dissolved as of the date of the filing of this annual report.

Information on Pacific Green Energy Parks Limited

Pacific Green Energy Parks Limited (“PGEP”) sees an opportunity to develop renewable power stations with capacities up to 50MW in the biomass and waste to energy sectors. In addition to their positive impact on the world’s environment, these projects have the potential to deliver a sustainable post-tax equity IRR and may provide our company with an opportunity to deploy its technologies. To this end our company has been identifying and investigating appropriate projects worldwide.

On March 26, 2012, PGEP reached an agreement with the shareholders of Energy Park Sutton Bridge Limited (“EPSB”), whereby PGEP would fund a planning application for the development of a biomass energy plant in return for a 75% shareholding in EPSB. EPSB was incorporated in the UK in 2009 to develop a 49 MW biomass energy plant in Sutton Bridge, Lincolnshire, UK. A planning application for EPSB was submitted to South Holland District Council (“SHDC”) on September 4, 2012.

On March 5, 2013, PGEP acquired the remaining 25% of EPSB. On May 8, 2013, EPSB secured planning permission for a 49MW biomass power plant at Sutton Bridge, Lincolnshire.

The facility will have an installed energy capacity of 49MW. The export capacity of the facility will be circa 44MW. The electricity will be supplied to the National Grid. Heat from the operation will be used within the facility and the ancillary buildings whilst off-take points will be provided for future combined heat and power needs in the area. The location of the plant alongside an existing industrial estate and in proximity of an area proposed for future industrial expansion makes the realization of the potential for combined heat and power more likely than in other possible locations. EPSB has secured options to purchase the freehold of the Energy Park site from the land owners.

Biomass is considered to be carbon neutral because the quantity of CO₂ released during combustion is the same as that absorbed by plants as a result of photosynthesis during their growth. This differs from fossil fuels in that, although both originating from organic matter, the carbon in fossil fuels has been locked away for millions of years, and when released during combustion, results in a net increase in CO₂ levels in the atmosphere.

Biomass is also considered environmentally sustainable as in many cases it is derived from by-products of other industries such as agriculture and forestry management. This contains a closed carbon cycle with no net increase in atmospheric CO₂ levels. As a result, EPSB will be entitled to renewables obligation certificates (“ROCs”) under the UK’s Renewable Obligation regime. As of April 2016, pure biomass will be afforded 1.4 ROCs/MWh of electricity produced, for a 20 year tariff period. EPSB’s forecasts assume:

EPSB will recover energy from virgin wood using steam turbine technology. The plant will require approximately 325,000 tonnes of virgin wood per annum (“Feedstock”).

Following discussions with industry experts, engineers, consultants and financiers, our company estimates that EPSB should cost approximately £165,000,000 to construct. Once the project is “spade ready”, construction should take 2 years. Previously, we anticipated that the project would be “spade ready” by March 2014. However, our company’s application for planning consent was not accepted by council and we resubmitted our application on June 20, 2014. The EPC contractor will provide a fixed cost turnkey completion guarantee. Planning consent was again turned down April 2015.

A detailed carbon assessment has been submitted within the EIA presenting the carbon savings offered by the operation of the facility.

The project will deliver combined heat and power (“CHP”) infrastructure. Our company is investigating potential opportunities for supplying local heat customers at both existing and potential new developments off site. EPSB will maintain an open dialogue with the local authority and will ensure that an appropriate boiler and turbine design is selected to facilitate the distribution of heat.

Currently our company is identifying and assessing further renewable power plant developments that are complimentary to the use of ENVI-Emissions Systems where possible.

Securing additional financial and human capital

We have limited capital and four directors. It is anticipated that we will expand our management team to fully exploit the representation agreement and it will also therefore be necessary to raise financial capital. We anticipate that we will need to raise additional financial capital through equity issuances, debt instruments and guarantees.

Form of any subsequent acquisitions

The manner in which we participate in an opportunity will depend upon the nature of the opportunity, our respective needs and desires and those of the promoters of the opportunity, and our relative negotiating strength compared to that of such promoters.

It is likely that we will acquire further participations in business opportunities through the issuance of our common stock, or other of our securities. Although the terms of any such transaction cannot be predicted, it should be noted that in certain circumstances the criteria for determining whether or not an acquisition is a so-called “tax free” reorganization under Section 368(a)(1) of the Internal Revenue Code of 1986, as amended, or the Code, depends upon whether the owners of the acquired business own 80% or more of the voting stock of the surviving entity. If a transaction were structured to take advantage of these provisions rather than other “tax free” provisions provided under the Code, all prior stockholders would in such circumstances retain 20% or less of the total issued and outstanding shares of the surviving entity. Under other circumstances, depending upon the relative negotiating strength of the parties, prior stockholders may retain substantially less than 20% of the total issued and outstanding shares of the surviving entity. This could result in substantial additional dilution to the equity of those who were our stockholders prior to such reorganization.

Our stockholders will likely not have control of a majority of our voting securities following a reorganization transaction. As part of such a transaction, our directors may resign and one or more new directors may be appointed without any vote by stockholders.

In the case of an acquisition, the transaction may be accomplished upon the sole determination of management without any vote or approval by our stockholders. In the case of a statutory merger or consolidation directly involving our company, it will likely be necessary to call a stockholders’ meeting and obtain the approval of the holders of a majority of our outstanding securities. The necessity to obtain such stockholder approval may result in delay and additional expense in the consummation of any proposed transaction and will also give rise to certain appraisal rights to dissenting stockholders. Most likely, management will seek to structure any such transaction so as not to require stockholder approval.

It is anticipated that the investigation of specific business opportunities and the negotiation, drafting and execution of relevant agreements, disclosure documents and other instruments will require substantial management time and attention and substantial cost for accountants, attorneys and others. If a decision is made not to participate in a specific business opportunity, the costs theretofore incurred in the related investigation might not be recoverable. Furthermore, even if an agreement is reached for the participation in a specific business opportunity, the failure to consummate that transaction may result in the loss to us of the related costs incurred.

Other Business Matters

On April 3, 2013, we entered into and closed a share exchange agreement with certain shareholders of EnviroTechnologies. Pursuant to the terms of the share exchange agreement, we agreed to acquire 17,653,872 issued and outstanding common shares of EnviroTechnologies from the shareholders in exchange for the issuance of 1,765,395 shares of the common stock of our company. We issued an aggregate of 1,765,395 common shares to 47 shareholders.

On April 25, 2013, we entered into and closed share exchange agreements with certain shareholders of EnviroTechnologies. Pursuant to the terms of the share exchange agreement, we agreed to acquire 6,682,357 issued and outstanding common shares of EnviroTechnologies from the shareholders in exchange for the issuance of 668,238 shares of common stock of our company. We issued an aggregate of 668,238 common shares to 20 shareholders.

On May 15, 2013, we entered into and closed a stock purchase agreement with all five of the shareholders of Pacific Green Energy Parks Limited ("PGEP"), a company incorporated in the British Virgin Islands. PGEP is the sole shareholder of Energy Park Sutton Bridge Limited, a company incorporated in the United Kingdom. PGEP is developing a biomass power plant facility and holds an option to purchase the real property upon which the facility will be built.

Pursuant to the stock purchase agreement, we agreed to acquire all of the 1,752 issued and outstanding common shares of PGEP from the shareholders in exchange for:

1. a payment of \$100 upon execution of the stock purchase agreement, which has been paid by us;
2. \$14,000,000 paid in common shares in our capital stock at a deemed price at the lower of \$4 per share or the average closing price per share of our capital stock in the ten trading days immediately preceding the date of closing of the stock purchase agreement, which have been issued by us;
3. \$3,000,000 payable in common shares of our capital stock at a deemed price at the lower of \$4 per share or the average closing price per share of our capital stock in the ten trading days immediately preceding the date upon which PGEP either purchases the property or secures a lease permitting PGEP to operate the facility on the property, which has not yet occurred; and
4. subject to leasing or purchasing the property and PGEP securing sufficient financing for the construction of the facility, \$33,000,000 payable in common shares of our capital stock at a deemed price at the lower of \$4 per share or the average closing price per share of our capital stock in the ten trading days immediately preceding the date that PGEP secures sufficient financing for the construction of the facility, which has not yet occurred.

All consideration from our company to the shareholders has been and will be issued on a pro-rata, pari-passu basis in proportion to the respective number of shares of PGEP sold by each respective shareholder. On May 15, 2013, pursuant to the stock purchase agreement, we issued an aggregate of 3,500,000 common shares, at an agreed upon deemed price of \$4 per share, to the five shareholders.

Pacific Green Energy Parks Limited and its wholly owned subsidiary, Energy Park Sutton Bridge, are now subsidiaries of our company.

On May 17, 2013, we entered into a debt settlement agreement with EnviroTechnologies and EnviroResolutions (collectively, the "**Debtors**"). Pursuant to the terms of the debt settlement agreement, we agreed to release and waive all obligations of the Debtors to repay debts, in the aggregate of \$293,406 and CAD\$38,079, to us and agreed to return an aggregate of 88,876,443 common shares of EnviroTechnologies to EnviroResolutions. The 88,876,443 common shares of EnviroTechnologies were returned as of June 30, 2016. As consideration for this release and waiver and return of shares, the Debtors agreed to transfer all rights, interests and title to certain intellectual property, the physical embodiments of such intellectual property, and to the supplemental agreement dated March 5, 2013 among EnviroResolutions, PREL and Green Energy Parks Limited ("**GEPL**") (collectively, the "**Debtors' Assets**").

The Debtors' Assets include the intellectual property rights throughout most of the world for the ENVI-Clean™ system, the ENVI-Pure™ system and the ENVI-SEA™ scrubber. The ENVI-Clean™ system removes most of the sulphur dioxide, particulate matter, greenhouse gases and other hazardous air pollutants from the flue gases produced by the combustion of coal, biomass, municipal solid waste, diesel and other fuels. The ENVI-Pure™ emission system combines the ENVI-Clean™ highly effective patent-pending wet scrubbing technology with an innovative wet electrostatic precipitator and a granular activated carbon adsorber to remove particulate matter, acid gases, regulated metals, dioxins and VOCs from the flue gas to levels significantly below those required by strictest international regulations. The ENVI-SEA™ scrubber can be applied to diesel exhaust emissions that require sulphur and particulate matter abatement. Using seawater on a single-pass basis as the scrubbing fluid in combination with its patent pending scrubbing head will provide a highly interactive zone of turbulent mixing for absorption of SO₂, particulate matter and other pollutants from the engine's exhaust.

The following is a brief description of further terms and conditions of the debt settlement agreement that are material to our company:

1. We pay 25% of all funds, if any, received under the supplemental agreement to the Debtors within 14 days upon receipt of funds, if any, pursuant to the supplemental agreement;
2. We enter into definitive agreements with the Debtors to:
 - a. license the Debtors' Assets back to the Debtors, under arm's length commercial terms, for use in the USA and Canada, with the exception of NRG Energy, Inc. and Edison Mission and affiliates; and
 - b. have the Debtors provide engineering services to us on terms to be agreed upon, acting reasonably;
3. The Debtors pay pro-rata any third party broker fees and legal fees, if any, that are subsequent costs associated with the Supplemental Agreement; and
4. the Debtors retain possession of, yet make a pilot-scale scrubber available for rental to our company at a nominal cost.

On June 11, 2013, we submitted 24,336,229 common shares of EnviroTechnologies to EnviroTechnologies for cancellation pursuant to our debt settlement agreement with EnviroTechnologies and EnviroResolutions dated May 17, 2013.

Pursuant to a debt settlement agreement dated May 17, 2013 among our company, EnviroTechnologies and EnviroResolutions, on November 22, 2013, our company was transferred a 40% shareholding in PREL by GEPL (who had, prior to this transfer, held all the issued and outstanding shares of PREL). PREL is a limited liability company incorporated under the laws of the United Kingdom.

PREL was incorporated by GEPL to develop a 79MWe waste to energy power station at Peterborough, United Kingdom (the "**Peterborough Plant**"). The Peterborough Plant has full planning permission at 79MWe and environmental agency permits. It is understood that the Peterborough Plant will be built in two stages at a total capital cost of approximately GBP£500 million (approximately US\$824,534,442). As of May 17, 2013, PREL owned 20% of Energy Park Investments Limited, the holding company that is currently intended to finance the development of the Peterborough Plant in turn through its wholly owned operating subsidiary Energy Park Peterborough Limited.

On June 17, 2013, we entered into and closed share exchange agreements with certain shareholders of EnviroTechnologies. Pursuant to the terms of the share exchange agreements we acquired 8,061,286 issued and outstanding common shares of EnviroTechnologies from the shareholders in exchange for the issuance of 806,132 shares of common stock of our company. We issued an aggregate of 806,132 shares of common stock to 19 shareholders.

On August 6, 2013, we entered into two share exchange agreements with two shareholders of EnviroTechnologies. Pursuant to the terms of the agreements, we acquired 440,000 issued and outstanding common shares of EnviroTechnologies from one shareholder in exchange for shares of common stock of our company on a 1 for 10 basis. Pursuant to the terms of the other agreement, we acquired 600,000 issued and outstanding common shares of EnviroTechnologies from one shareholder in exchange for shares of common stock of our company on a 1 for 15 basis.

On August 27, 2013, we entered into share exchange agreements with certain shareholders of EnviroTechnologies. Pursuant to the terms of the agreements, we acquired 32,463,489 issued and outstanding common shares of EnviroTechnologies from the shareholders in exchange for shares of common stock of our company on a 1 for 10 basis.

On September 13, 2013, we submitted 41,564,775 common shares of EnviroTechnologies to EnviroTechnologies for cancellation pursuant to our debt settlement agreement with EnviroTechnologies and EnviroResolutions dated May 17, 2013.

On September 26, 2013, we entered into an agreement with Andrew Jolly, wherein Dr. Jolly agreed to serve as a director of our company. Pursuant to the agreement, our company is to compensate Dr. Jolly for serving as a director of our company at GBP£2,000 (approximately \$3,235) per calendar month. Effective October 1, 2013, we appointed Dr. Jolly as a director of our company. Effective September 1, 2014, the monthly fee for Dr. Jolly was reduced to GBP£1,000 (approximately \$1,617).

On October 11, 2013, we entered into share exchange agreements with certain shareholders of EnviroTechnologies. Pursuant to the terms of the agreements, we agreed to acquire 674,107 issued and outstanding common shares of EnviroTechnologies from the shareholders in exchange for shares of common stock of our company on a 1 for 10 basis.

On December 18, 2013, we announced that our company engaged BlueMount Capital to spearhead the development of its proprietary emission control technologies, ENVI-Clean™ and ENVI-Pure™, in the People's Republic of China ("PRC"). In addition to corporate finance advisory services both within and outside China, BlueMount offers a tailored service to clients wishing to enter the PRC market with a particular emphasis on companies that own proprietary technology, intellectual property and expertise. To that end, BlueMount provides a comprehensive suite of services to enhance the effectiveness and long-term sustainability of foreign brands entering the PRC market. Our Company's strategic objective is to establish an operating presence in China with established local partners and rapidly rollout its technologies.

On December 27, 2013, we entered into and closed share exchange agreements with certain shareholders of EnviroTechnologies. Pursuant to the terms of the share exchange agreements, we acquired 130,000 issued and outstanding common shares of EnviroTechnologies from the shareholders in exchange for shares of common stock of our company on a 1 for 10 basis. On December 27, 2013, we issued an aggregate of 13,000 common shares to the shareholders of EnviroTechnologies.

On January 27, 2014, we entered into an agreement with Pöyry Management Consulting (UK) Limited. Pursuant to the agreement, Pöyry is to provide consulting services to us. Our company has agreed to compensate Pöyry a minimum of £5,000 (approximately \$ 8,293) as consulting fees for the first year of the agreement and a variable hourly rate as set out in the agreement.

On May 27, 2014, we entered into a \$200,000 convertible debenture with Intrawest Overseas Limited. Under the terms of the debenture, the amount is unsecured, bears interest at 10% per annum, and is due on May 27, 2015. Pursuant to the agreement, should any portion of loan remain outstanding past maturity the interest will increase to 15% per annum. The note is convertible into shares of common stock 180 days after the date of issuance (November 27, 2014) until maturity at a conversion rate of 75% of the average offer price of our company's common stock for the 45 days ending one trading day prior to the date the conversion notice is sent by the holder to our company.

Our company analyzed the conversion option under ASC 815, "Accounting for Derivative Instruments and Hedging Activities", and determined that the conversion feature should be classified as a liability and recorded at fair value due to there being no explicit limit to the number of shares to be delivered upon settlement of the conversion option. In accordance with ASC 815, our company recognized the intrinsic value of the embedded beneficial conversion feature of \$33,922. On November 27, 2014, the note became convertible resulting in our company recording a derivative liability of \$33,922 with a corresponding adjustment to loss on change in fair value of derivative liabilities.

On June 12, 2014, we entered into a \$100,000 convertible debenture with Gerstle Consulting Pty Limited. Under the terms of the debenture, the amount is unsecured, bears interest at 10% per annum, and is due on June 12, 2015. Pursuant to the agreement, should any portion of loan remain outstanding past maturity the interest will increase to 15% per annum. The note is convertible into shares of common stock 180 days after the date of issuance (December 12, 2014) until maturity at a conversion rate of 75% of the average closing bid prices of our company's common stock for the 45 days ending one trading day prior to the date the conversion notice is sent by the holder to our company.

Our company analyzed the conversion option under ASC 815, "Accounting for Derivative Instruments and Hedging Activities", and determined that the conversion feature should be classified as a liability and recorded at fair value due to there being no explicit limit to the number of shares to be delivered upon settlement of the conversion option. In accordance with ASC 815, our company recognized the intrinsic value of the embedded beneficial conversion feature of \$9,793. On December 12, 2014, the note became convertible resulting in our company recording a derivative liability of \$9,793 with a corresponding adjustment to loss on change in fair value of derivative liabilities.

On June 30, 2015, through our wholly owned subsidiary, Pacific Green Energy Parks Limited, we purchased all of the issued and outstanding shares in Pacific Green Technologies Asia Limited for \$1.00 from Alexander Shead.

We entered into an agreement dated July 20, 2015 with Mr. Alexander Shead. Pursuant to this agreement, Mr. Shead has agreed to serve as a director of our company. As a director of our company, Mr. Shead shall be compensated \$1,000 for every calendar month of the term of the agreement. The term of the agreement is for 12 months. On July 20, 2015, we appointed Mr. Shead as a director of our company.

On September 22, 2015, our company entered into a consulting agreement (the "Agreement") with Midam Ventures, LLC ("Midam") wherein Midam will provide investor relations and business advisory services to us from September 23, 2015 to March 23, 2016. Any compensation described in the Agreement shall be deemed earned and vested by Midam even in the case of early termination of the Agreement.

Pursuant to the terms of the Agreement, we will to pay \$30,000 in cash and 200,000 common restricted shares of our company to Midam. Effective October 20, 2015, we issued all of the shares pursuant to an exemption from registration relying on the provisions of Rule 506 of Regulation D promulgated under the *Securities Act of 1933*, as amended.

On October 24, 2015, our company entered into a marketing and consulting agreement with Red Rock Marketing Media, Inc. ("Red Rock") wherein Red Rock will provide investor relations and business advisory services to us for a period of 40 business days starting on or before the 10 business days after Red Rock receives compensation from our company. Pursuant to the terms of the Agreement, we will to pay \$100,000 in cash by October 29, 2015.

On October 27, 2015, our company entered into a loan agreement with a significant shareholder for proceeds of approximately \$4,231. The loan is unsecured, bears an interest rate of US Prime Rate plus 4%, and is due on demand.

On November 10, 2015, we issued a convertible note (the “**Note**”) to Tangiers Investment Group, LLC (“**Tangiers**”) in exchange for an aggregate of \$100,000 from Tangiers. The Note is for the aggregate sum of \$110,000 with 10% interest as an original issue discount and convertible into our common shares of (the “**Shares**”) at a price of equal to the lower of: (a) \$.40 per common share of our company or (b) 60% of the lowest trading price of our common stock during the 20 consecutive trading days prior to the date on which the holder of the Note elects to convert all or part of the Note.

On November 17, 2015, Pacific Green Technologies China Limited, a wholly-owned subsidiary of our company, entered into a commercial joint venture agreement with PowerChina SPEM Company Limited (“**PowerChina**”) wherein PowerChina would receive and process orders from our company for customers, and manufacture and install products as an engineering procurement construction process. In return, our company agreed to design the product and provide a technology license and technical supports to PowerChina. During the Agreement, we will provide PowerChina with a non-transferrable right and license to use Technology to manufacture and install our product within the Peoples’ Republic of China.

Upon receiving each order from us, PowerChina and we shall submit to each other the respective estimated budgets. For each project, after receipt of the revenue from the relevant customer, the budgets of our company and PowerChina shall be deducted and reimbursed from the revenue proportionally. We have agreed to share the gross profit pursuant to an even split of 50% to PowerChina and 50% to our company.

On July 14, 2017, the Company entered into a new memorandum of understanding to establish a new joint venture company in China with PowerChina (the "Supplier") wherein the Supplier would receive and process orders, manufacture, and install products for the Company's customers. In return, the Company agreed to design the product, provide strategic pricing, sales and marketing direction, as well as provide technology licenses and technical support (the "Technology") to the Supplier. During the term of the agreement, the Company will provide the Supplier with a non-transferrable right and license to use the Technology to manufacture and install the product within the Asia and Russia region.

The parties will fund the venture proportionately, 50.1% by the Company and 49.9% by the Supplier, and excess operating cash flows will be distributed on a quarterly basis.

Results of Operations

The following summary of our results of operations should be read in conjunction with our unaudited interim consolidated financial statements for the six months ended September 30, 2018 and 2017.

Our net loss for the six month periods ended September 30, 2018 and 2017 are summarized as follows:

	Three Months Ended September 30,		Six Months Ended September 30,	
	2018	2017	2018	2017
Advertising and promotion	\$ 69,425	\$ 8,100	\$ 103,942	\$ 23,950
Amortization of intangible assets	\$ 218,954	\$ 218,953	\$ 437,907	\$ 437,906
Consulting fees	\$ 830,887	\$ 76,996	\$ 1,187,971	\$ 178,799
Depreciation	\$ 2,356	\$ 2,357	\$ 4,712	\$ 4,713
Foreign exchange loss (gain)	\$ (20,845)	\$ (50,556)	\$ (165,574)	\$ 47,915
Office and miscellaneous	\$ 17,653	\$ 16,866	\$ 80,296	\$ 63,697
Professional fees	\$ 88,405	\$ 49,760	\$ 157,947	\$ 89,289
Research and development	\$ -	\$ 377,660	\$ -	\$ 429,964
Salaries and wages	\$ 171,364	\$ -	\$ 171,364	\$ -
Stock-based compensation	\$ 174,249	\$ -	\$ 174,249	\$ -
Transfer agent and filing fees	\$ 10,359	\$ 12,550	\$ 27,381	\$ 25,851
Travel	\$ 128,494	\$ 75,919	\$ 211,988	\$ 126,338
Interest expense	\$ 3,035	\$ 75,296	\$ 6,025	\$ 343,999
Impairment of property and equipment	\$ -	\$ 290,580	\$ -	\$ 290,580
Gain on extinguishment of debt	\$ -	\$ (97,631)	\$ -	\$ (97,631)
Loss on change in fair value of derivative liabilities	\$ 35,719	\$ 179,309	\$ 180,866	\$ 284,369
Net Loss	\$ (1,730,055)	\$ (1,236,159)	\$ (2,579,074)	\$ (2,249,739)

Operating expenses for the six month period ended September 30, 2018 were \$2,392,183 as compared to \$1,428,422 for the six month period ended September 30, 2017. The increase in expenses was primarily in advertising and promotion, consulting fees, and travel as part of the Company's efforts to market its product and services to ship owners globally.

For the three month period ended September 30, 2018, our Company had a net loss of \$1,730,055 (\$0.04 per share) compared to a net loss of \$1,236,159 (\$0.04 per share) for the three month period ended September 30, 2017. In addition to the operating expenses noted above, for the three month period ended September 30, 2018, our company had interest expense of \$3,035 and loss on change in fair value of derivative liabilities of \$35,719 as compared to interest expense of \$75,296, gain on extinguishment of debt of \$97,631, impairment of property and equipment of \$290,580 and a loss on change in fair value of derivative liabilities of \$179,309 for the three month period ended September 30, 2017. The increase in net loss is primarily related to increases in consulting, salaries and wages and stock-based compensation and a decrease in impairment on property and equipment.

Liquidity and Capital Resources

Working Capital

	As at September 30, 2018	As at March 31, 2018
Current Assets	\$ 1,890,639	\$ 331,927
Current Liabilities	\$ 1,131,351	\$ 1,223,809
Working Capital (Deficit)	\$ 759,288	\$ (891,882)

Cash Flows

	Six Months Ended September 30, 2018	Six Months Ended September 30, 2017
Net cash used in operating activities	\$ (2,173,790)	\$ (793,972)
Net cash used in investing activities	\$ -	\$ (669,466)
Net cash provided by financing activities	\$ 2,936,000	\$ 1,190,844
Effect of foreign exchange	\$ (116,124)	\$ 40,800
Net increase in cash	\$ 646,086	\$ (231,754)
Cash, End of Period	\$ 875,968	\$ 150,413

As of September 30, 2018, we had \$875,968 in cash, other current assets of \$1,014,671, a long-term lease receivable of \$1,995,000, and total liabilities of \$1,131,351. As of March 31, 2018, we had working capital of \$759,288.

During the six months ended September 30, 2018, we spent \$2,173,790 on operating activities, whereas \$793,972 was spent on operating activities for the six month period ended September 30, 2017.

During the six months ended September 30, 2018, we used \$Nil in investing activities, whereas we used \$669,466 in investing activities during the six months ended September 30, 2017.

During the six months ended September 30, 2018, we received \$2,936,000 from financing activities, which consisted of proceeds from securities purchase agreements, whereas we received \$1,190,884 from financing activities during the six months ended September 30, 2017.

Anticipated Cash Requirements

We may require additional funds to fund our budgeted expenses over the next 12 months. These funds may be raised through equity financing, debt financing, or other sources, which may result in further dilution in the equity ownership of our shares.

We anticipate that our cash expenses over the next 12 months will be approximately \$3,150,000 as described in the table below. These estimates may change significantly depending on the nature of our business activities and our ability to raise capital from our shareholders or other sources.

Description	Estimated Expenses (\$)
Legal and accounting fees	300,000
Marketing and advertising	250,000
Investor relations and capital raising	150,000
Engineering, research and technical development	600,000
Travel	450,000
Management and operating costs	500,000
Salaries and consulting fees	650,000
General and administrative expenses	250,000
Total	3,150,000

Our general and administrative expenses for the year will consist primarily of transfer agent fees, bank and interest charges and rent and general office expenses. The professional fees are related to our regulatory filings throughout the year and include legal, accounting and auditing fees.

Based on our planned expenditures, we require a minimum of \$2,300,000 to proceed with our business plan over the next 12 months. As of September 30, 2018, we had \$875,968 cash on hand

Should our business plans change, requiring additional cash resources, we would intend to raise the balance of our cash requirements from private placements, the exercise of warrants and options, or possibly a registered public offering (either self-underwritten or through a broker-dealer). If we are unsuccessful in raising enough money through such efforts, we may review other financing possibilities such as bank loans. At this time we do not have a commitment from any broker-dealer to provide us with financing. There is no assurance that any financing will be available to us or if available, on terms that will be acceptable to us.

Going Concern

Our condensed consolidated financial statements for the six month period ended September 30, 2018 have been prepared on a going concern basis and contain an additional explanatory paragraph which identifies issues that raise substantial doubt about our ability to continue as a going concern. Our financial statements do not include any adjustments that might result from the outcome of this uncertainty.

The continuation of the Company as a going concern is dependent upon the continued financial support from its shareholders, creditors, and related parties, and the ability of the Company to generate profitable operations. As at September 30, 2018, the Company has begun commercial sales generating revenues; the Company has an accumulated deficit of \$70,343,125. A history of significant losses raises doubts regarding the Company's ability to continue as a going concern.

If our operations and cash flow improve, management believes that we can continue to operate. However, no assurance can be given that management's actions will result in profitable operations or an improvement in our liquidity situation. The threat of our ability to continue as a going concern will cease to exist only when our revenues have reached a level able to sustain our business operations.

Off-Balance Sheet Arrangements

We have no significant off-balance sheet arrangements that have or are reasonably likely to have a current or future effect on our financial condition, revenues or expenses, results of operations, liquidity, capital expenditures or capital resources that are material to stockholders.

Critical Accounting Policies

Use of Estimates

The preparation of these consolidated financial statements in conformity with U.S. generally accepted accounting principles requires management to make estimates and assumptions that affect the reported amounts of assets and liabilities and disclosure of contingent assets and liabilities at the date of the financial statements and the reported amounts of revenue and expenses during the reporting period. Our company regularly evaluates estimates and assumptions related to the useful life and recoverability of intangible assets, valuation of note payable, fair value of convertible debentures, fair value of derivative liabilities, fair value of stock-based compensation, impairment of goodwill, and deferred income tax asset valuation allowances. Our company bases its estimates and assumptions on current facts, historical experience and various other factors that it believes to be reasonable under the circumstances, the results of which form the basis for making judgments about the carrying values of assets and liabilities and the accrual of costs and expenses that are not readily apparent from other sources. The actual results experienced by our company may differ materially and adversely from our company's estimates. To the extent there are material differences between the estimates and the actual results, future results of operations will be affected.

Intangible Assets

Intangible assets are stated at cost less accumulated amortization and are comprised of patents. The patents are amortized straight-line over the estimated useful life of 17 years.

Impairment of Long-lived Assets

Our company reviews long-lived assets such as property and equipment and intangible assets with finite useful lives for impairment whenever events or changes in circumstance indicate that the carrying amount may not be recoverable. If the total of the expected undiscounted future cash flows is less than the carrying amount of the asset, a loss is recognized for the excess of the carrying amount over the fair value of the asset.

Revenue recognition

The Company recognizes revenues when equipment has been delivered and accepted by a customer and risk of ownership has transferred. In addition, terms and pricing has been finalized and the collectability of proceeds is reasonably assured. The energy management lease arrangement qualifies for sales-type lease accounting and includes an option for the transfer of title at the conclusion of the lease payments.

Stock-based compensation

Our company records stock-based compensation in accordance with ASC 718, "Compensation – Stock Compensation", using the fair value method. All transactions in which goods or services are the consideration received for the issuance of equity instruments are accounted for based on the fair value of the consideration received or the fair value of the equity instrument issued, whichever is more reliably measurable.

Our company uses the Black-Scholes option pricing model to calculate the fair value of stock-based awards. This model is affected by our company's stock price as well as assumptions regarding a number of subjective variables. These subjective variables include, but are not limited to our company's expected stock price volatility over the term of the awards, and actual and projected employee stock option exercise behaviors. The value of the portion of the award that is ultimately expected to vest is recognized as an expense in the consolidated statement of operations over the requisite service period.

Recent Accounting Pronouncements

In February 2016, the FASB issued new lease accounting guidance in ASU No. 2016-02, "Leases". This new guidance was initiated as a joint project with the International Accounting Standards Board to simplify lease accounting and improve the quality of and comparability of financial information for users. This new guidance would eliminate the concept of off-balance sheet treatment for "operating leases" for lessees for the vast majority of lease contracts. Under ASU No. 2016-02, at inception, a lessee must classify all leases with a term of over one year as either finance or operating, with both classifications resulting in the recognition of a defined "right-of-use" asset and a lease liability on the balance sheet. However, recognition in the income statement will differ depending on the lease classification, with finance leases recognizing the amortization of the right-of-use asset separate from the interest on the lease liability and operating leases recognizing a single total lease expense. Lessor accounting under ASU No. 2016-02 would be substantially unchanged from the previous lease requirements under GAAP. ASU No. 2016-02 will take effect for public companies in fiscal years beginning after December 15, 2018, including interim periods within those fiscal years. Early adoption is permitted and for leases existing at, or entered into after, the beginning of the earliest comparative period presented in the financial statements, lessees and lessors must apply a modified retrospective transition approach. The Company is currently evaluating the new guidance and has not determined the impact this standard may have on the consolidated financial statements.

Our company has implemented all new accounting pronouncements that are in effect and that may impact its consolidated financial statements. At this time, management does not believe that there are any other new accounting pronouncements that have been issued that might have a material impact on its financial position or results of operations.

Item 3. Quantitative and Qualitative Disclosures About Market Risk

As a smaller reporting company, we are not required to provide the information required by this Item.

Item 4. Controls and Procedures

Evaluation of Disclosure Controls and Procedures

We maintain disclosure controls and procedures that are designed to ensure that information required to be disclosed in our reports filed under the *Securities Exchange Act of 1934*, as amended, is recorded, processed, summarized and reported within the time periods specified in the Securities and Exchange Commission's rules and forms, and that such information is accumulated and communicated to our management, including our president (our principal executive officer, principal financial officer and principal accounting officer) to allow for timely decisions regarding required disclosure.

As of the end of our quarter covered by this report, we carried out an evaluation, under the supervision and with the participation of our president (our principal executive officer, principal financial officer and principal accounting officer), of the effectiveness of the design and operation of our disclosure controls and procedures. Based on the foregoing, our president (our principal executive officer, principal financial officer and principal accounting officer) concluded that our disclosure controls and procedures were not effective as of the end of the period covered by this quarterly report.

Changes in Internal Control over Financial Reporting

During the period covered by this report, management has implemented certain controls and procedures to mitigate material weakness previously identified by management in the company's internal controls over financial reporting.

Cash Controls – The Company's implemented dual authorization processes for banking transactions and segregated, where possible, accounting and payment procedures.

Information Technology Controls – The Company's revised its policies around data retention, to include routine daily server backups and off-site cloud storage for organizational data and expanded upon its firewall and network security measures.

PART II – OTHER INFORMATION

Item 1. Legal Proceedings

We know of no material, existing or pending legal proceedings against our company, nor are we involved as a plaintiff in any material proceeding or pending litigation. There are no proceedings in which any of our directors, officers or affiliates, or any registered beneficial shareholder, is an adverse party or has a material interest adverse to our interest.

Item 1A. Risk Factors

As a “smaller reporting company” we are not required to provide the information required by this Item.

Item 2. Unregistered Sales of Equity Securities

On April 28, 2018, the Company issued 206,675 shares of common stock relating to a non-brokered private placement at a price of \$1.00 per share for proceeds of \$206,675. The securities were issued to three (3) non-US persons (as that term is defined in Regulation S of the Securities Act of 1933), in an offshore transaction relying on Regulation S of the Securities Act of 1933, as amended

On May 29, 2018, the Company issued 1,957,333 shares of common stock relating to a non-brokered private placement at a price of \$1.50 per share for proceeds of \$2,936,000. The securities were issued to seven (7) non-US persons (as that term is defined in Regulation S of the Securities Act of 1933), in an offshore transaction relying on Regulation S of the Securities Act of 1933, as amended

Item 3. Defaults Upon Senior Securities

None.

Item 4. Mine Safety Disclosures

Not applicable.

Item 5. Other Information

None.

Item 6. Exhibits

Exhibit Number	Description
(2)	Plan of Acquisition, Reorganization, Arrangement Liquidation or Succession
2.1	Assignment and Share Transfer Agreement dated June 14, 2012 between our company, Pacific Green Technologies Limited and Pacific Green Group Limited (incorporated by reference to our Registration Statement on Form 10 filed on July 3, 2012)
(3)	Articles of Incorporation and Bylaws
3.1	Articles of Incorporation filed on July 3, 2012 (incorporated by reference to our Registration Statement on Form 10 filed on July 3, 2012)
3.2	Certificate of Amendment filed on August 15, 1995 (incorporated by reference to our Registration Statement on Form 10 filed on July 3, 2012)
3.3	Certificate of Amendment filed on August 5, 1998 (incorporated by reference to our Registration Statement on Form 10 filed on July 3, 2012)
3.4	Certificate of Amendment filed on October 15, 2002 (incorporated by reference to our Registration Statement on Form 10 filed on July 3, 2012)
3.5	Certificate of Amendment filed on May 8, 2006 (incorporated by reference to our Registration Statement on Form 10 filed on July 3, 2012)
3.6	Certificate of Amendment filed on May 29, 2012 (incorporated by reference to our Registration Statement on Form 10 filed on July 3, 2012)

Exhibit Number	Description
3.7	Bylaws filed on July 3, 2012 (incorporated by reference to our Registration Statement on Form 10 filed on July 3, 2012)
3.8	Certificate of Amendment filed on November 30, 2012 (incorporated by reference to our Current Report on Form 8-K filed on December 11, 2012)
(4)	Instruments Defining the Rights of Security Holders, Including Indentures
4.1	Share Certificate relating to shares held by our company in the Ordinary Share Capital of Peterborough Renewable Energy Limited (incorporated by reference to our Current Report on Form 8-K filed on December 12, 2013)
(10)	Material Contracts
10.1	Consulting Agreement dated May 1, 2010 between our company and Sichel Limited (incorporated by reference to our Registration Statement on Form 10, filed on July 3, 2012)
10.2	Representation Agreement dated June 7, 2010 between Pacific Green Group Limited and EnviroTechnologies, Inc. (incorporated by reference to our Registration Statement on Form 10, filed on July 3, 2012)
10.3	Peterborough Agreement dated October 5, 2011 between EnviroResolutions, Inc., Peterborough Renewable Energy Limited and Green Energy Parks Limited (incorporated by reference to our Registration Statement on Form 10, filed on July 3, 2012)
10.4	Promissory Note dated June 2012 between our company and Pacific Green Group Limited (incorporated by reference to our Registration Statement on Form 10, filed on July 3, 2012)
10.5	Assignment and Share Transfer Agreement dated June 14, 2012 between our company, Pacific Green Technologies Limited and Pacific Green Group Limited (incorporated by reference to our Registration Statement on Form 10, filed on July 3, 2012)
10.6	Non-Executive Director Agreement dated December 18, 2012 between our company and Neil Carmichael (incorporated by reference to our Current Report on Form 8-K filed on December 19, 2012)
10.7	Supplemental Agreement dated March 5, 2013 between EnviroResolutions, Inc., Peterborough Renewable Energy Limited and Green Energy Parks Limited (incorporated by reference to our Annual Report on Form 10-K filed on July 1, 2013)
10.8	Supplemental Agreement dated March 5, 2013 between our company, EnviroTechnologies Inc. and EnviroResolutions Inc. (incorporated by reference to our Current Report on Form 8-K filed on March 13, 2013)
10.9	Form of Share Exchange Agreement dated April 3, 2013 between our company and Shareholders of EnviroTechnologies Inc. (incorporated by reference to our Current Report on Form 8-K filed on April 8, 2013)
10.10	Form of Share Exchange Agreement dated April 25, 2013 between our company and Shareholders of EnviroTechnologies Inc. (incorporated by reference to our Current Report on Form 8-K filed on April 30, 2013)
10.11	Stock Purchase Agreement dated May 16, 2013 between our company and Shareholders of Pacific Green Energy Parks (incorporated by reference to our Current Report on Form 8-K/A filed on June 3, 2013)
10.12	Debt Settlement Agreement dated May 17, 2013 between our company, EnviroResolutions, Inc. and EnviroTechnologies, Inc. (incorporated by reference to our Current Report on Form 8-K/A filed on June 3, 2013)
10.13	Form of Share Exchange Agreement between our company and Shareholders of EnviroTechnologies, Inc. (incorporated by reference to our Current Report on Form 8-K filed on August 9, 2013)
10.14	Form of Share Exchange Agreement between our company and Shareholders of EnviroTechnologies, Inc. (incorporated by reference to our Current Report on Form 8-K filed on August 30, 2013)
10.15	Agreement dated September 26, 2013 between our company and Andrew Jolly (incorporated by reference to our Current Report on Form 8-K filed on October 3, 2013)
10.16	Form of Share Exchange Agreement between our company and Shareholders of EnviroTechnologies, Inc. (incorporated by reference to our Current Report on Form 8-K filed on October 22, 2013)
10.17	Agreement dated October 22, 2013 between our company and Chris Williams (incorporated by reference to our Current Report on Form 8-K filed on December 5, 2013)
10.18	Form of Subscription Agreement between our company and the subscribers (incorporated by reference to our Current Report on Form 8-K filed on December 24, 2013)

Exhibit Number	Description
10.19	Form of Share Exchange Agreement between our company and certain shareholders of EnviroTechnologies, Inc. (incorporated by reference to our Current Report on Form 8-K filed on December 27, 2013)
10.20	Agreement dated January 27, 2014 between our company and Pöyry Management Consulting (UK) Limited (incorporated by reference to our Quarterly Report on Form 10-Q filed on February 19, 2014)
10.21	Form of Subscription Agreement between our company and the subscribers (incorporated by reference to our Current Report on Form 8-K filed on March 11, 2014)
10.22	Loan Agreement between our company and Intrust Overseas Limited dated May 27, 2014 (incorporated by reference to our Quarterly Report on Form 10-Q filed on August 19, 2014)
10.23	Put Option Agreement between our company and Intrust Overseas Limited dated May 27, 2014 (incorporated by reference to our Quarterly Report on Form 10-Q filed on August 19, 2014)
10.24	Investor Relations Agreement dated September 22, 2015 between Pacific Green Technologies Inc. and Midam Ventures, LLC (incorporated by reference to our Current Report on Form 8-K filed on December 8, 2015).
10.25	Investor Relations Agreement dated October 24, 2015 between Pacific Green Technologies Inc. and Red Rock Marketing Media, Inc. (incorporated by reference to our Current Report on Form 8-K filed on December 21, 2015)
10.26	Convertible Note dated November 10, 2015 issued to Tangiers Investment Group, LLC (incorporated by reference to our Current Report on Form 8-K filed on November 24, 2015).
10.27	Commercial Joint Venture Agreement between PowerChina SPEM Company Limited and Pacific Green Technologies China Limited dated November 17, 2015 (incorporated by reference to our Current Report on Form 8-K filed on December 21, 2015).
(14)	Code of Ethics
14.1	Code of Ethics and Business Conduct (incorporated by reference to our Annual Report on Form 10-K filed on July 15, 2014)
(21)	Subsidiaries of the Registrant
21.1	Pacific Green Technologies Limited, a United Kingdom corporation (wholly owned); Pacific Green Energy Parks Limited, a British Virgin Islands corporation (wholly owned); Energy Park Sutton Bridge, a United Kingdom corporation (wholly owned by Pacific Green Energy Parks Limited).
(31)	Rule 13a-14 (d)/15d-14d) Certifications
31.1*	Section 302 Certification by the Principal Executive Officer, Principal Financial Officer and Principal Accounting Officer
(32)	Section 1350 Certifications
32.1*	Section 906 Certification by the Principal Executive Officer, Principal Financial Officer and Principal Accounting Officer
(99)	Additional Exhibits
99.1	Peterborough Renewable Energy Limited Directors' Report and Financial Statements for the period ended December 31, 2012 (incorporated by reference to our Current Report on Form 8-K filed on December 12, 2013)
101*	Interactive Data Files
101.INS	XBRL Instance Document
101.SCH	XBRL Taxonomy Extension Schema Document
101.CAL	XBRL Taxonomy Extension Calculation Linkbase Document
101.DEF	XBRL Taxonomy Extension Definition Linkbase Document
101.LAB	XBRL Taxonomy Extension Label Linkbase Document
101.PRE	XBRL Taxonomy Extension Presentation Linkbase Document

* Filed herewith.

SIGNATURES

Pursuant to the requirements of Section 13 or 15(d) of the Exchange Act, the registrant has duly caused this report to be signed on its behalf by the undersigned, thereunto duly authorized.

PACIFIC GREEN TECHNOLOGIES INC.
(Registrant)

Dated: November 19, 2018

By: /s/ Neil Carmichael
Neil Carmichael
President, Secretary, Treasurer and Director
(Principal Executive Officer, Principal Financial
Officer and Principal Accounting Officer)

**CERTIFICATION PURSUANT TO
18 U.S.C. ss 1350, AS ADOPTED PURSUANT TO
SECTION 302 OF THE SARBANES-OXLEY ACT OF 2002**

I, Neil Carmichael, certify that:

1. I have reviewed this quarterly report on Form 10-Q for September 30, 2018 of Pacific Green Technologies Inc.;
2. Based on my knowledge, this report does not contain any untrue statement of a material fact or omit to state a material fact necessary to make the statements made, in light of the circumstances under which such statements were made, not misleading with respect to the period covered by this report;
3. Based on my knowledge, the financial statements, and other financial information included in this report, fairly present in all material respects the financial condition, results of operations and cash flows of the registrant as of, and for, the periods presented in this report;
4. The registrant's other certifying officer(s) and I are responsible for establishing and maintaining disclosure controls and procedures (as defined in Exchange Act Rules 13a-15(e) and 15d-15(e)) and internal control over financial reporting (as defined in Exchange Act Rules 13a-15(f) and 15d-15(f)) for the registrant and have:
 - (a) Designed such disclosure controls and procedures, or caused such disclosure controls and procedures to be designed under our supervision, to ensure that material information relating to the registrant, including its consolidated subsidiaries, is made known to us by others within those entities, particularly during the period in which this report is being prepared;
 - (b) Designed such internal control over financial reporting, or caused such internal control over financial reporting to be designed under our supervision, to provide reasonable assurance regarding the reliability of financial reporting and the preparation of financial statements for external purposes in accordance with generally accepted accounting principles;
 - (c) Evaluated the effectiveness of the registrant's disclosure controls and procedures and presented in this report our conclusions about the effectiveness of the disclosure controls and procedures, as of the end of the period covered by this report based on such evaluation; and
 - (d) Disclosed in this report any change in the registrant's internal control over financial reporting that occurred during the registrant's most recent fiscal quarter (the registrant's fourth fiscal quarter in the case of an annual report) that has materially affected, or is reasonably likely to materially affect, the registrant's internal control over financial reporting; and
5. The registrant's other certifying officer(s) and I have disclosed, based on our most recent evaluation of internal control over financial reporting, to the registrant's auditors and the audit committee of the registrant's board of directors (or persons performing the equivalent functions):
 - (a) All significant deficiencies and material weaknesses in the design or operation of internal control over financial reporting which are reasonably likely to adversely affect the registrant's ability to record, process, summarize and report financial information; and
 - (b) Any fraud, whether or not material, that involves management or other employees who have a significant role in the registrant's internal control over financial reporting.

Date: November 19, 2018

/s/ Neil Carmichael

Neil Carmichael
President, Secretary, Treasurer and Director
(Principal Executive Officer, Principal Financial Officer
and Principal Accounting Officer)
Pacific Green Technologies Inc.

**CERTIFICATION PURSUANT TO
18 U.S.C. SECTION 1350, AS ADOPTED PURSUANT TO
SECTION 906 OF THE SARBANES-OXLEY ACT OF 2002**

I, Neil Carmichael, hereby certify, pursuant to 18 U.S.C. Section 1350, as adopted pursuant to Section 906 of the Sarbanes-Oxley Act of 2002, that:

- (1) the Quarterly Report on Form 10-Q of Pacific Green Technologies Inc. for the period ended September 30, 2018 (the “**Report**”) fully complies with the requirements of Section 13(a) or 15(d) of the Securities Exchange Act of 1934; and
- (2) the information contained in the Report fairly presents, in all material respects, the financial condition and results of operations of Pacific Green Technologies Inc.

Dated: November 19, 2018

/s/ Neil Carmichael

Neil Carmichael

President, Secretary, Treasurer and Director
(Principal Executive Officer, Principal Financial
Officer and Principal Accounting Officer)
Pacific Green Technologies Inc.

A signed original of this written statement required by Section 906, or other document authenticating, acknowledging, or otherwise adopting the signature that appears in typed form within the electronic version of this written statement required by Section 906, has been provided to Pacific Green Technologies Inc. and will be retained by Pacific Green Technologies Inc. and furnished to the Securities and Exchange Commission or its staff upon request.