

**UNITED STATES  
SECURITIES AND EXCHANGE COMMISSION  
Washington, D.C. 20549**

**FORM 10-K**

(Mark One)

ANNUAL REPORT PURSUANT TO SECTION 13 OR 15(d) OF THE SECURITIES EXCHANGE ACT OF 1934

For the fiscal year ended **March 31, 2016**

TRANSITION REPORT UNDER SECTION 13 OR 15(d) OF THE SECURITIES EXCHANGE ACT OF 1934

For the transition period from [            ] to [            ]

Commission file number **000-54756**

**PACIFIC GREEN TECHNOLOGIES INC.**

(Exact name of registrant as specified in its charter)

**Delaware**

(State or other jurisdiction of  
incorporation or organization)

**N/A**

(I.R.S. Employer  
Identification No.)

**5205 Prospect Road, Suite 135-226, San Jose, CA**

(Address of principal executive offices)

**95129**

(Zip Code)

Registrant's telephone number, including area code: **(408) 538-3373**

Securities registered pursuant to Section 12(b) of the Act:

Title of Each Class

**N/A**

Name of Each Exchange On Which Registered

**N/A**

Securities registered pursuant to Section 12(g) of the Act:

**Shares of Common Stock, par value \$0.001**

(Title of class)

Indicate by check mark if the registrant is a well-known seasoned issuer, as defined in Rule 405 of the Securities Act. Yes  No

Indicate by check mark if the registrant is not required to file reports pursuant to Section 13 or Section 15(d) of the Act. Yes  No

Indicate by check mark whether the registrant: (1) has filed all reports required to be filed by Section 13 or 15(d) of the Securities Exchange Act of 1934 during the preceding 12 months (or for such shorter period that the registrant was required to file such reports) and (2) has been subject to such filing requirements for the last 90 days. Yes  No

Indicate by check mark whether the registrant has submitted electronically and posted on its corporate Website, if any, every Interactive Data File required to be submitted and posted pursuant to Rule 405 of Regulation S-K (§229.405 of this chapter) during the preceding 12 months (or for such shorter period that the registrant was required to submit and post such files). Yes  No

Indicate by check mark if disclosure of delinquent filers pursuant to Item 405 of Regulation S-K (§229.405 of this chapter) is not contained herein, and will not be contained, to the best of registrant's knowledge, in definitive proxy or information statements incorporated by reference in Part III of this Form 10-K or any amendment to this Form 10-K.

Indicate by check mark whether the registrant is a large accelerated filer, an accelerated filer, a non-accelerated filer, or a smaller reporting company. See definition of "large accelerated filer," "accelerated filer" and "smaller reporting company" in Rule 12b-2 of the Exchange Act.

Large accelerated filer

Accelerated filer

Non-accelerated filer

Smaller reporting company

Indicate by check mark whether the registrant is a shell company (as defined in Rule 12b-2 of the Exchange Act). Yes  No

The aggregate market value of Common Stock held by non-affiliates of the Registrant on September 30, 2013 was \$57,425,170.14 based on a \$6.62 average bid and asked price of such common equity, as of the last business day of the registrant's most recently completed second fiscal quarter.

Indicate the number of shares outstanding of each of the registrant's classes of common stock as of the latest practicable date.

23,908,576 common shares issued and outstanding as of August 15, 2016.

DOCUMENTS INCORPORATED BY REFERENCE

None.

## Table of Contents

Item 1. Business	1
Item 1A. Risk Factors	14
Item 1B. Unresolved Staff Comments	18
Item 2. Properties	18
Item 3. Legal Proceedings	19
Item 4. Mine Safety Disclosures	19
Item 5. Market for Registrant's Common Equity, Related Stockholder Matters and Issuer Purchases of Equity Securities	19
Item 6. Selected Financial Data	21
Item 7. Management's Discussion and Analysis of Financial Condition and Results of Operations	21
Item 7A. Quantitative and Qualitative Disclosures About Market Risk	24
Item 8. Financial Statements and Supplementary Data	24
Item 9A. Controls and Procedures	26
Item 9B. Other Information	27
Item 10. Directors, Executive Officers and Corporate Governance	28
Item 11. Executive Compensation	33
Item 12. Security Ownership of Certain Beneficial Owners and Management and Related Stockholder Matters	35
Item 13. Certain Relationships and Related Transactions, and Director Independence	36
Item 14. Principal Accounting Fees and Services	37
Item 15. Exhibits, Financial Statement Schedules	38

---

## **Item 1. Business**

This annual report contains forward-looking statements. These statements relate to future events or our future financial performance. In some cases, you can identify forward-looking statements by terminology such as “may”, “should”, “expects”, “plans”, “anticipates”, “believes”, “estimates”, “predicts”, “potential” or “continue” or the negative of these terms or other comparable terminology. These statements are only predictions and involve known and unknown risks, uncertainties and other factors, including the risks in the section entitled “Risk Factors”, that may cause our or our industry’s actual results, levels of activity, performance or achievements to be materially different from any future results, levels of activity, performance or achievements expressed or implied by these forward-looking statements.

Although we believe that the expectations reflected in the forward-looking statements are reasonable, we cannot guarantee future results, levels of activity, performance or achievements. Except as required by applicable law, including the securities laws of the United States, we do not intend to update any of the forward-looking statements to conform these statements to actual results.

Our financial statements are stated in United States Dollars (US\$) and are prepared in accordance with United States Generally Accepted Accounting Principles.

In this annual report, unless otherwise specified, all dollar amounts are expressed in United States dollars and all references to “common shares” refer to the common shares in our capital stock.

As used in this annual report and unless otherwise indicated, the terms “we”, “us”, “our” and “our company” mean Pacific Green Technologies Inc., a Delaware corporation, and our wholly owned subsidiaries, Pacific Green Technologies Limited, a United Kingdom corporation, Pacific Green Energy Parks Limited, a British Virgin Islands corporation, and its wholly owned subsidiary, Energy Park Sutton Bridge, a United Kingdom corporation, unless otherwise indicated.

### **Corporate History**

Our company was incorporated in Delaware on March 10, 1994, under the name of Beta Acquisition Corp. In September 1995, we changed our name to In-Sports International, Inc. In August 2002, we changed our name from In-Sports International, Inc. to ECash, Inc. In 2007, due to limited financial resources, we discontinued our operations. Over the course of the last five years, we have sought new business opportunities.

On June 13, 2012, we changed our name to Pacific Green Technologies Inc. and effected a reverse split of our common stock following which we had 27,002 shares of common stock outstanding with \$0.001 par value.

Effective December 4, 2012, we filed with the Delaware Secretary of State a Certificate of Amendment of Certificate of Incorporation, wherein we increased our authorized share capital to 510,000,000 shares of stock as follows:

- 500,000,000 shares of common stock with a par value of \$0.001; and
- 10,000,000 shares of preferred stock with a par value of \$0.001.

The increase of authorized capital was approved by our board of directors on July 1, 2012 and by a majority of our stockholders by a resolution dated July 1, 2012.

### ***Historical Business Overview***

On May 1, 2010 we entered into a consulting agreement with Sichel Limited. Sichel has investigated new opportunities for us and has subscribed for new shares of our company’s common stock. The consulting agreement entitles Sichel to \$20,000 per calendar month. With an effective date of March 31, 2013, the consulting agreement, along with all amounts owed to Sichel, were assigned to Pacific Green Group Limited (“**PGG**”). As at our year ended March 31, 2015, we owed Sichel \$Nil and we owed PGG approximately GBP295,438, USD\$1,058,269 and CAD\$4,362,768. Pursuant to the terms of the consulting agreement, if we are unable to pay the monthly consulting fee, PGG may elect to be paid in shares of stock, and if we are unable to make payments for more than six months in any 12 month period, PGG has the right to appoint an officer or director to the board, which right has not been exercised at this time.

## ***New Strategy***

Management, assisted by PGG, has identified an opportunity to build a business focused on marketing, developing and acquiring technologies designed to improve the environment by reducing pollution. To this end we entered into and closed an assignment and share transfer agreement, on June 14, 2012, for the assignment of a representation agreement and the acquisition of a company involved in the environmental technology industry.

The assignment and share transfer agreement provided for the acquisition of 100% of the issued and outstanding shares of Pacific Green Technologies Limited, formerly PGG's subsidiary in the United Kingdom. Additionally, PGG has assigned to our company a ten year exclusive worldwide representation agreement with EnviroTechnologies Inc., (formerly EnviroResolutions, Inc.), a Delaware corporation, to market and sell EnviroTechnologies' current and future environmental technologies. The representation agreement entitles PGG to a commission of 20% of all sales (net of taxes) generated by EnviroTechnologies. Pursuant to the terms of the assignment and share transfer agreement, all rights and obligations under the representation agreement have been transferred to our company. We currently anticipate that sales under the representation agreement will be our sole source of revenue for the foreseeable future. We had intended to complete an acquisition of EnviroTechnologies, as this would have been a logical step in our development. However, as discussed herein, we have settled with EnviroTechnologies as an alternative.

Both Sichel and PGG are wholly owned subsidiaries of the Hookipia Trust. PGG's wholly owned subsidiary was Pacific Green Technologies Limited. As a result, we acquired Pacific Green Technologies Limited from PGG. Sichel is a significant shareholder of our company and also provides us with consulting services. The sole director of Sichel is also the sole director of PGG. Further, PGG is a significant shareholder of EnviroTechnologies.

The assignment and share transfer agreement closed on June 14, 2012 via the issuance of 5,000,000 shares of our common stock as well as a \$5,000,000 promissory note to PGG. We have consequently undertaken the operations of Pacific Green Technologies Limited and PGG's obligations under the representation agreement.

Full consideration contemplated by the assignment and share transfer agreement was \$25,000,000 satisfied through the issue of 5,000,000 new shares of our common stock at a price of \$4 per share with the balance of \$5,000,000 structured as a promissory note over the next five years as follows:

- June 12, 2013, \$1,000,000 (which amount remains outstanding and has been rolled over to the following payment date);
- June 12, 2014, \$1,000,000 (this amount remains unpaid);
- June 12, 2015, \$1,000,000 (this amount remains unpaid);
- June 12, 2016, \$1,000,000; and
- June 12, 2017, \$1,000,000.

Under the terms of the promissory note, the loan repayments specified above shall not exceed the amount we earn under the terms of the representation agreement. If we are unable to meet the repayment schedule set out above, PGG will have the option to either roll over any unpaid portion to the following payment date or to convert the outstanding amount into new shares of our common stock. However, the entire amount of the promissory note is due upon the maturity date on the fifth anniversary. The promissory note is unsecured.

The total consideration of \$25,000,000 was a purchase price not determined under U.S. GAAP, and both the \$25,000,000 total price and the deemed price of \$4 per share does not represent the fair value of the stock issued or a value used in accounting for the acquisition. The number of shares issued and the terms of the promissory note were negotiated between the parties and are intended to represent full consideration for the acquisition of Pacific Green Technologies Limited and the representation agreement.

## ***Information on EnviroTechnologies***

EnviroTechnologies, a company incorporated in Delaware, has protected intellectual property rights throughout most of the world for its ENVI-Clean™ Emissions System ("ENVI-Clean™"). The ENVI-Clean™ system removes most of the sulphur dioxide, particulate matter, greenhouse gases and other hazardous air pollutants from the flue gases produced by the combustion of coal, biomass, municipal solid waste, diesel and other fuels.

The ENVI-Clean™ system is comprised of five components:

- an induced draft fan ("ID fan");
- a gas conditioning chamber;
- the ENVI-Clean™ unit;
- a demister; and
- settling tanks.

The ID fan creates the pressure differential required to force the gas through the scrubbing fluid suspended on each head and move it through the other components in the system. The gas conditioning chamber cools the hot flue gas prior to entering the ENVI-Clean™ System. The ENVI-Clean™ System contains the heads and the demister pads at the exhaust exit. The neutralizing fluid is constantly circulated and cleaned by mechanical means with the contaminated component of the separation going to a settling tank prior to dewatering. The settled solids are disposed of with the bottom ash produced by the combustion process.

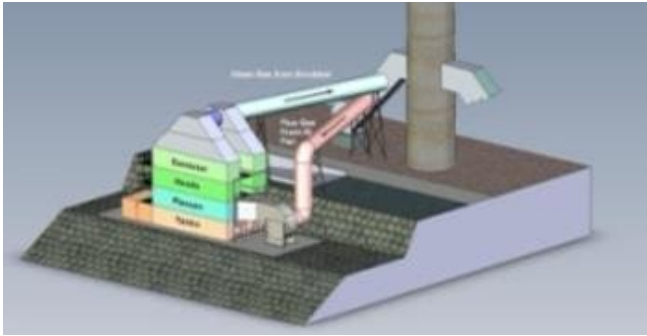

The ENVI-CES™ technology forces 100% of the polluted exhaust flue gas into the neutralizing fluid to produce a highly turbulent interaction between the target pollutants and the fluid. The aggressive mixing produces small bubbles which create a very high surface contact area between the exhaust gas and fluid to enhance the transfer of particulate and targeted gaseous and hazardous pollutants from the exhaust to the fluid.

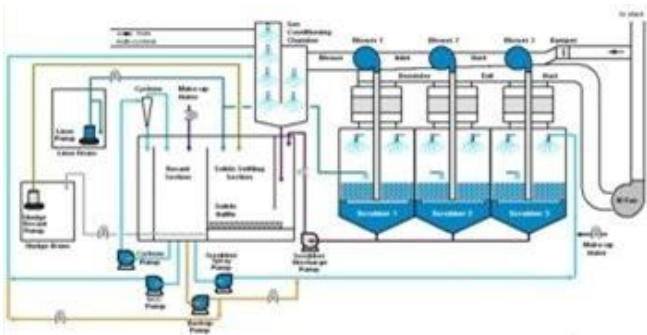

*Schematic of the ENVI-Clean™ Emission's System as installed for Biomass applications*

Unique to the ENVI approach is the introduction of the gas in the lower section of the ENVI-Clean™ unit which makes the greatest portion of its cross section available for fluid–gas interaction. This permits a smaller and highly flexible footprint. Furthermore, the system design allows for multiple heads each containing different neutralizing fluids to remove various pollutants from the flue gas. The ordered removal of acid and greenhouse gases within a single unit makes the system highly desirable by industries whose fuels contain multiple contaminants. The resulting ENVI-Clean™ unit has high efficiency and is very simple to operate.

The neutralizing solution is selected to remove targeted pollutants: limestone and hydrated lime are used to neutralize the scrubbing solution for the removal of acid gases such as sulphur dioxide, hydrogen chloride and hydrogen fluoride. The unique design of the ENVI system allows for the sequential removal of pollutants by stacking heads and utilizing different neutralizing chemistry in each operating unit. This provides industry with a system that fulfills multiple applications.

The ENVI-Clean™ system has numerous new and retrofit applications:

- coal and coal waste fuelled CFBC boilers;
- pulverized coal and stoker-grate boilers;
- heavy oil fired boilers;
- biomass and waste to energy boilers;
- lime kilns, dryers, shredders and foundries;
- industrial exhaust scrubbing of particulates and acid gases;
- diesel engines, large marine and stationary engines; and
- sewage sludge, hazardous waste and MSW incinerators.

Our management believes that the ENVI-Clean™ system has significant competitive advantages in the market for emission control systems including:

1. *Efficiency*: tests performed at an 84MW coal power plant in West Virginia (USA) indicate that the ENVI-Clean™ system removed on average 99.3% of sulfur dioxide over a three day period from the plant's emissions;
2. *Low Capital Cost*: the system has a compact and flexible footprint relative to competitive products. For electricity generation applications, EnviroTechnologies' system is priced for market at approximately \$90 per kilowatt of electricity generation. In comparison, industry consultants state that comparable systems in North America are typically priced at \$300-500 per kilowatt (Source: High Energy Services/Babcock & Wilson-wet scrubber systems for SO<sub>2</sub> removal in North America);
3. *Low Ongoing Operating Cost*: the ENVI-Clean™ system is more affordable in the long term for customers compared to competitor products;
4. *New and Retrofit Applications*: for retrofit applications in particular (as required by the 2011 EPA Boiler MACT Requirements), the system is considered by management to be more compact and adaptable than rival systems;
5. *Scalability*: the ENVI-Clean™ system can be adapted for the largest power stations but also smaller applications such as diesel marine engines. It can also remove multiple pollutants in a single system, unlike much of the competition.

On October 5, 2011, EnviroResolutions, a British Columbia corporation, signed a contract to supply the ENVI-Clean™ system to a new waste to energy plant being built in Peterborough, United Kingdom (the "Peterborough Contract"). The initial material term and condition of the contract was that EnviroResolutions demonstrate testing of the system that achieved the performance levels represented in regards to emissions by March 31, 2012. This condition was successfully satisfied and confirmed with Peterborough Renewable Energy Limited ("PREL") prior to the required date. The Peterborough Contract entitles us, as the holder of the representation agreement, to a commission of approximately \$4,600,000 before third party agency fees.

Effective March 5, 2013, we entered into a supplemental agreement with EnviroTechnologies and EnviroResolutions. The supplemental agreement amends the representation agreement between PGG and EnviroTechnologies dated June 7, 2010, which was later assigned to us from PGG in connection with an assignment and share transfer agreement dated June 14, 2012. The supplemental agreement entitles our company to a commission of equal to 50% (previously 20%) of any licensing revenue that may be generated by EnviroTechnologies Inc. in respect of its existing and future technologies.

In addition, pursuant to the supplemental agreement, we will receive from EnviroResolutions an amount equal to 50% of any assets or consideration received as compensation from PREL for PREL's failure to perform under a contingent sale agreement dated October 5, 2011 between EnviroResolutions and PREL. We will receive the fee for our assistance to EnviroResolutions during their negotiations with PREL regarding PREL's failure to perform. The fee, if any, provided to us will not constitute any repayment of our loans that were made to EnviroResolutions.

The supplemental agreement supplements the Peterborough Contract dated October 5, 2011 entered into among EnviroResolutions, PREL and GEPL. Pursuant to the Peterborough Contract, EnviroResolutions was to supply PREL with a wet scrubbing emission control system to a new waste to energy plant being built in Peterborough, United Kingdom.

#### ***Information on Pacific Green Technologies Limited***

Pacific Green Technologies Limited is a limited liability company incorporated under the laws of England and Wales on April 5, 2011 ("PGT"). The director of PGT is Mr. Joseph Grigor Kelly. On November 7, 2012, Mr. Joseph Grigor Kelly tendered his resignation to the board of directors. PGT has no employees. Concurrently, Neil Carmichael consented to and was appointed as the sole director and chief executive and financial officer of PGT.

The purpose of incorporating PGT was to utilize local knowledge and contacts to build a platform for sales in the following regions: Western Europe, Eastern Europe, Russian Federation, Turkey, Middle East, Azerbaijan, Kazakhstan and Africa. However, our company has found that the cost to have physical presence in England far out weights the benefit. As a result, PGT is now in the process of being dissolved as of the date of the filing of this annual report.

### ***Information on Pacific Green Energy Parks Limited***

Pacific Green Energy Parks Limited (“PGEP”) sees an opportunity to develop renewable power stations with capacities up to 50MW in the biomass and waste to energy sectors. In addition to their positive impact on the world’s environment, these projects have the potential to deliver a sustainable post-tax equity IRR and may provide our company with an opportunity to deploy its technologies. To this end our company has been identifying and investigating appropriate projects worldwide.

On March 26, 2012, PGEP reached an agreement with the shareholders of Energy Park Sutton Bridge Limited (“EPSB”), whereby PGEP would fund a planning application for the development of a biomass energy plant in return for a 75% shareholding in EPSB. EPSB was incorporated in the UK in 2009 to develop a 49 MW biomass energy plant in Sutton Bridge, Lincolnshire, UK. A planning application for EPSB was submitted to South Holland District Council (“SHDC”) on September 4, 2012.

On March 5, 2013, PGEP acquired the remaining 25% of EPSB. On May 8, 2013, EPSB secured planning permission for a 49MW biomass power plant at Sutton Bridge, Lincolnshire.

The facility will have an installed energy capacity of 49MW. The export capacity of the facility will be circa 44MW. The electricity will be supplied to the National Grid. Heat from the operation will be used within the facility and the ancillary buildings whilst off-take points will be provided for future combined heat and power needs in the area. The location of the plant alongside an existing industrial estate and in proximity of an area proposed for future industrial expansion makes the realization of the potential for combined heat and power more likely than in other possible locations. EPSB has secured options to purchase the freehold of the Energy Park site from the land owners.

Biomass is considered to be carbon neutral because the quantity of CO<sub>2</sub> released during combustion is the same as that absorbed by plants as a result of photosynthesis during their growth. This differs from fossil fuels in that, although both originating from organic matter, the carbon in fossil fuels has been locked away for millions of years, and when released during combustion, results in a net increase in CO<sub>2</sub> levels in the atmosphere.

Biomass is also considered environmentally sustainable as in many cases it is derived from by-products of other industries such as agriculture and forestry management. This contains a closed carbon cycle with no net increase in atmospheric CO<sub>2</sub> levels. As a result, EPSB will be entitled to renewables obligation certificates (“ROCs”) under the UK’s Renewable Obligation regime. As of April 2016, pure biomass will be afforded 1.4 ROCs/MWh of electricity produced, for a 20 year tariff period. EPSB’s forecasts assume:

EPSB will recover energy from virgin wood using steam turbine technology. The plant will require approximately 325,000 tonnes of virgin wood per annum (“Feedstock”).

Following discussions with industry experts, engineers, consultants and financiers, our company estimates that EPSB should cost approximately £165,000,000 to construct. Once the project is “spade ready”, construction should take 2 years. Previously, we anticipated that the project would be “spade ready” by March 2014. However, our company’s application for planning consent was not accepted by council and we resubmitted our application on June 20, 2014. The EPC contractor will provide a fixed cost turnkey completion guarantee. Planning consent was turned down April 2015 again.

A detailed carbon assessment has been submitted within the EIA presenting the carbon savings offered by the operation of the facility.

The project will deliver combined heat and power (“CHP”) infrastructure. Our company is investigating potential opportunities for supplying local heat customers at both existing and potential new developments off site. EPSB will maintain an open dialogue with the local authority and will ensure that an appropriate boiler and turbine design is selected to facilitate the distribution of heat.

A debt information memorandum has been produced by PwC for raising funding for the EPSB project.

Currently our company is identifying and assessing further renewable power plant developments that are complimentary to the use of ENVI-Emissions Systems where possible.

## Current Business

Since signing the representation agreement, PGG has secured a worldwide network of agents to market the ENVI-Clean™ system. In Europe there are four agents, in North America there are five agents, in Asia and Australia there are two agents, and in the Middle East there is one agent. We have assumed these relationships as part of the assignment and continue to pursue the following main areas of focus.

### *i) Waste to Energy Plants across Europe*

Increasing legislation relating to landfill of municipal solid waste has led to the emergence of increasing numbers of waste to energy plants (“WtE”). A WtE plant obviates the need for landfill, burning municipal waste for conversion to electricity. A WtE plant is typically 45-100MW. The ENVI-Clean™ system is particularly suited to WtE as it cleans multiple pollutants in a single system. The contract secured by EnviroResolutions in Peterborough (UK) relates to a WtE plant and the ENVI-Clean™ system was successfully tested at a WtE plant in Edmonton (UK) in March 2012.

### *ii) Coal fired power stations in North America and Asia*

EnviroResolutions has successfully conducted sulphur dioxide demonstration tests at the American Bituminous Coal Partners power plant in Grant Town, West Virginia. The testing achieved a three test average of 99.3% removal efficiency. The implementation of US Clean Air regulations in July 2010 has created additional demand for sulphur dioxide removal in all industries emitting sulphur pollution. Furthermore, China consumes approximately one half of the world’s coal, but introduced measures designed to reduce energy and carbon intensity in its 12th Five Year Plan.

### *iii) Biomass*

Applications include regional power facilities and heating for commercial buildings and greenhouses. Typical applications range in size from 1 to 20 megawatts (MW) with power generation occupying the larger end of the range. ENVI has operated a pilot ENVI-clean™ scrubber designed to remove particulate from a 6MW boiler used to heat a large scale, greenhouse facility. The optimization and testing took place in late 2009 through to March 2010 at the Katatheon Farms in Langley, British Columbia. The full scale system was purchased by the farm and installed in 2010.

### *iv) Land and marine diesel*

Diesel exhaust includes ash and soot as particulate components and sulphur dioxide as an acid gas. The ENVI-Clean™ system is applicable for land power generation systems and marine engines. Diesel power has particular relevance in remote settings such as mining, oil and gas exploration camps in emerging nations.

Testing has been conducted on diesel shipping to confirm the application of seawater as a neutralizing agent for sulphur emissions. In addition to marine application these tests showed applicability of the system for large displacement engines such as stationary generators, compressors, container handling, heavy construction and mining equipment.

Our company continues to analyze new business opportunities under each of the categories stated above. As of the date of this annual report and with the exception of the agreements disclosed in this document, we have not entered into any definitive agreement with any party, nor have there been any specific discussions with any potential business combination candidates regarding business opportunities for us. We have unrestricted flexibility in seeking, analyzing and participating in potential business opportunities.

In accordance with our business purpose and strategy outlined above, our efforts to analyze potential business opportunities will consider the following factors:

- potential for growth, indicated by new technology, anticipated market expansion or new products;
- competitive position as compared to other firms of similar size and experience within the industry segment as well as within the industry as a whole;
- strength and diversity of management, either in place or scheduled for recruitment;
- capital requirements and anticipated availability of required funds, to be provided by us or from operations, through the sale of additional securities, through joint ventures or similar arrangements or from other sources;
- the cost of participation by us as compared to the perceived tangible and intangible values and potentials;
- the extent to which the business opportunity can be advanced;
- the accessibility of required management expertise, personnel, raw materials, services, professional assistance and other required items; and
- other relevant factors



In applying the foregoing criteria, no one of which will be controlling, management will attempt to analyze all factors and circumstances and make a determination based upon reasonable investigative measures and available data. Potential business opportunities may occur at various stages of development, all of which will make the task of comparative investigation and analysis of such business opportunities extremely difficult and complex. Due to our limited capital available for investigation, we may not discover or adequately evaluate adverse facts about the opportunity to be acquired.

### **Securing additional financial and human capital**

We have limited capital and three directors. It will be necessary for us to build a management team to fully exploit the representation agreement and it will also therefore be necessary to raise financial capital. We will therefore proactively seek the raising of additional financial capital as part of our new strategy.

### **Form of any subsequent acquisitions**

The manner in which we participate in an opportunity will depend upon the nature of the opportunity, our respective needs and desires and those of the promoters of the opportunity, and our relative negotiating strength compared to that of such promoters.

It is likely that we will acquire further participations in business opportunities through the issuance of our common stock, or other of our securities. Although the terms of any such transaction cannot be predicted, it should be noted that in certain circumstances the criteria for determining whether or not an acquisition is a so-called "tax free" reorganization under Section 368(a)(1) of the Internal Revenue Code of 1986, as amended, or the Code, depends upon whether the owners of the acquired business own 80% or more of the voting stock of the surviving entity. If a transaction were structured to take advantage of these provisions rather than other "tax free" provisions provided under the Code, all prior stockholders would in such circumstances retain 20% or less of the total issued and outstanding shares of the surviving entity. Under other circumstances, depending upon the relative negotiating strength of the parties, prior stockholders may retain substantially less than 20% of the total issued and outstanding shares of the surviving entity. This could result in substantial additional dilution to the equity of those who were our stockholders prior to such reorganization.

Our stockholders will likely not have control of a majority of our voting securities following a reorganization transaction. As part of such a transaction, our directors may resign and one or more new directors may be appointed without any vote by stockholders.

In the case of an acquisition, the transaction may be accomplished upon the sole determination of management without any vote or approval by our stockholders. In the case of a statutory merger or consolidation directly involving our company, it will likely be necessary to call a stockholders' meeting and obtain the approval of the holders of a majority of our outstanding securities. The necessity to obtain such stockholder approval may result in delay and additional expense in the consummation of any proposed transaction and will also give rise to certain appraisal rights to dissenting stockholders. Most likely, management will seek to structure any such transaction so as not to require stockholder approval.

It is anticipated that the investigation of specific business opportunities and the negotiation, drafting and execution of relevant agreements, disclosure documents and other instruments will require substantial management time and attention and substantial cost for accountants, attorneys and others. If a decision is made not to participate in a specific business opportunity, the costs theretofore incurred in the related investigation might not be recoverable. Furthermore, even if an agreement is reached for the participation in a specific business opportunity, the failure to consummate that transaction may result in the loss to us of the related costs incurred.

### **Other Business Matters**

Effective December 18, 2012, we entered into a non-executive director agreement with Dr. Neil Carmichael, wherein Dr. Carmichael will receive compensation of \$1,000 per year for the term of the agreement and was granted options to purchase up to 62,500 shares of common stock at an exercise price of \$0.01 per share of common stock. The options will terminate the earlier of 24 months, or upon the termination of the agreement and Dr. Carmichael's engagement with our company. As of the date of this annual report, the options to Dr. Carmichael have not been exercised.

On April 3, 2013, we entered into and closed a share exchange agreement with certain shareholders of EnviroTechnologies. Pursuant to the terms of the share exchange agreement, we agreed to acquire 17,653,872 issued and outstanding common shares of EnviroTechnologies from the shareholders in exchange for the issuance of 1,765,395 shares of the common stock of our company. We issued an aggregate of 1,765,395 common shares to 47 shareholders.

On April 25, 2013, we entered into and closed share exchange agreements with certain shareholders of EnviroTechnologies. Pursuant to the terms of the share exchange agreement, we agreed to acquire 6,682,357 issued and outstanding common shares of EnviroTechnologies from the shareholders in exchange for the issuance of 668,238 shares of common stock of our company. We issued an aggregate of 668,238 common shares to 20 shareholders.

On May 15, 2013, we entered into and closed a stock purchase agreement with all five of the shareholders of Pacific Green Energy Parks Limited ("PGEP"), a company incorporated in the British Virgin Islands. PGEP is the sole shareholder of Energy Park Sutton Bridge Limited, a company incorporated in the United Kingdom. PGEP is developing a biomass power plant facility and holds an option to purchase the real property upon which the facility will be built.

Pursuant to the stock purchase agreement, we agreed to acquire all of the 1,752 issued and outstanding common shares of PGEP from the shareholders in exchange for:

1. a payment of \$100 upon execution of the stock purchase agreement, which has been paid by us;
2. \$14,000,000 paid in common shares in our capital stock at a deemed price at the lower of \$4 per share or the average closing price per share of our capital stock in the ten trading days immediately preceding the date of closing of the stock purchase agreement, which have been issued by us;
3. \$3,000,000 payable in common shares of our capital stock at a deemed price at the lower of \$4 per share or the average closing price per share of our capital stock in the ten trading days immediately preceding the date upon which PGEP either purchases the property or secures a lease permitting PGEP to operate the facility on the property, which has not yet occurred; and
4. subject to leasing or purchasing the property and PGEP securing sufficient financing for the construction of the facility, \$33,000,000 payable in common shares of our capital stock at a deemed price at the lower of \$4 per share or the average closing price per share of our capital stock in the ten trading days immediately preceding the date that PGEP secures sufficient financing for the construction of the facility, which has not yet occurred.

All consideration from our company to the shareholders has been and will be issued on a pro-rata, pari-passu basis in proportion to the respective number of shares of PGEP sold by each respective shareholder. On May 15, 2013, pursuant to the stock purchase agreement, we issued an aggregate of 3,500,000 common shares, at an agreed upon deemed price of \$4 per share, to the five shareholders.

Pacific Green Energy Parks Limited and its wholly owned subsidiary, Energy Park Sutton Bridge, are now subsidiaries of our company.

On May 17, 2013, we entered into a debt settlement agreement with EnviroTechnologies and EnviroResolutions (collectively, the "Debtors"). Pursuant to the terms of the debt settlement agreement, we agreed to release and waive all obligations of the Debtors to repay debts, in the aggregate of \$293,406 and CAD\$38,079, to us and agreed to return an aggregate of 88,876,443 (as of March 31, 2015, 2,217,130 common shares of EnviroTechnologies remain to be returned) common shares of EnviroTechnologies to EnviroResolutions. As consideration for this release and waiver and return of shares, the Debtors agreed to transfer all rights, interests and title to certain intellectual property, the physical embodiments of such intellectual property, and to the supplemental agreement dated March 5, 2013 among EnviroResolutions, PREL and Green Energy Parks Limited ("GEPL") (collectively, the "Debtors' Assets").

The Debtors' Assets include the intellectual property rights throughout most of the world for the ENVI-Clean™ system, the ENVI-Pure™ system and the ENVI-SEA™ scrubber. The ENVI-Clean™ system removes most of the sulphur dioxide, particulate matter, greenhouse gases and other hazardous air pollutants from the flue gases produced by the combustion of coal, biomass, municipal solid waste, diesel and other fuels. The ENVI-Pure™ emission system combines the ENVI-Clean™ highly effective patent-pending wet scrubbing technology with an innovative wet electrostatic precipitator and a granular activated carbon adsorber to remove particulate matter, acid gases, regulated metals, dioxins and VOCs from the flue gas to levels significantly below those required by strictest international regulations. The ENVI-SEA™ scrubber can be applied to diesel exhaust emissions that require sulphur and particulate matter abatement. Using seawater on a single-pass basis as the scrubbing fluid in combination with its patent pending scrubbing head will provide a highly interactive zone of turbulent mixing for absorption of SO<sub>2</sub>, particulate matter and other pollutants from the engine's exhaust.

The following is a brief description of further terms and conditions of the debt settlement agreement that are material to our company:

1. we pay 25% of all funds, if any, received under the supplemental agreement to the Debtors within 14 days upon receipt of funds, if any, pursuant to the supplemental agreement;
2. we enter into definitive agreements with the Debtors to:
  - a. license the Debtors' Assets back to the Debtors, under arm's length commercial terms, for use in the USA and Canada, with the exception of NRG Energy, Inc. and Edison Mission and affiliates; and
  - b. have the Debtors provide engineering services to us on terms to be agreed upon, acting reasonably;
3. the Debtors pay pro-rata any third party broker fees and legal fees, if any, that are subsequent costs associated with the Supplemental Agreement; and
4. the Debtors retain possession of, yet make a pilot-scale scrubber available for rental to our company at a nominal cost.

On June 11, 2013, we submitted 24,336,229 common shares of EnviroTechnologies to EnviroTechnologies for cancellation pursuant to our debt settlement agreement with EnviroTechnologies and EnviroResolutions dated May 17, 2013.

Pursuant to a debt settlement agreement dated May 17, 2013 among our company, EnviroTechnologies and EnviroResolutions, on November 22, 2013, our company was transferred a 40% shareholding in PREL by GEPL (who had, prior to this transfer, held all the issued and outstanding shares of PREL). PREL is a limited liability company incorporated under the laws of the United Kingdom.

PREL was incorporated by GEPL to develop a 79MWe waste to energy power station at Peterborough, United Kingdom (the "Peterborough Plant"). The Peterborough Plant has full planning permission at 79MWe and environmental agency permits. It is understood that the Peterborough Plant will be built in two stages at a total capital cost of approximately GBP£500 million (approximately US\$824,534,442). As of May 17, 2013, PREL owns 20% of Energy Park Investments Limited, the holding company that is currently intended to finance the development of the Peterborough Plant in turn through its wholly owned operating subsidiary Energy Park Peterborough Limited.

On June 17, 2013, we entered into and closed share exchange agreements with certain shareholders of EnviroTechnologies. Pursuant to the terms of the share exchange agreements we agreed to acquire 8,061,286 issued and outstanding common shares of EnviroTechnologies from the shareholders in exchange for the issuance of 806,132 shares of common stock of our company. We issued as aggregate of 806,132 shares of common stock to 19 shareholders.

On August 6, 2013, we entered into two share exchange agreements with two shareholders of EnviroTechnologies. Pursuant to the terms of the agreements, we agreed to acquire 440,000 issued and outstanding common shares of EnviroTechnologies from one shareholder in exchange for shares of common stock of our company on a 1 for 10 basis. Pursuant to the terms of the other agreement, we agreed to acquire 600,000 issued and outstanding common shares of EnviroTechnologies from one shareholder in exchange for shares of common stock of our company on a 1 for 15 basis.

On August 27, 2013, we entered into share exchange agreements with certain shareholders of EnviroTechnologies. Pursuant to the terms of the agreements, we have agreed to acquire 32,463,489 issued and outstanding common shares of EnviroTechnologies from the shareholders in exchange for shares of common stock of our company on a 1 for 10 basis.

On September 13, 2013, we submitted 41,564,775 common shares of EnviroTechnologies to EnviroTechnologies for cancellation pursuant to our debt settlement agreement with EnviroTechnologies and EnviroResolutions dated May 17, 2013.

On September 26, 2013, we entered into an agreement with Andrew Jolly, wherein Dr. Jolly agreed to serve as a director of our company. Pursuant to the agreement, our company is to compensate Dr. Jolly for serving as a director of our company at GBP£2,000 (approximately \$3,235) per calendar month. Effective October 1, 2013, we appointed Dr. Jolly as a director of our company.

On October 11, 2013, we entered into share exchange agreements with certain shareholders of EnviroTechnologies. Pursuant to the terms of the agreements, we have agreed to acquire 674,107 issued and outstanding common shares of EnviroTechnologies from the shareholders in exchange for shares of common stock of our company on a 1 for 10 basis.

On October 22, 2013, we entered into an agreement with Mr. Chris Williams, wherein Mr. Williams agreed to serve as business development director of our company effective December 5, 2013. As business development director of our company, Mr. Williams was to focus on developing potential new business opportunities and generating sales from our existing assets

Pursuant to the agreement, our company agreed to compensate Mr. Williams for serving as a business development director of our company with:

- GBP£450 (approximately \$730) per day and a guarantee of a minimum of four days a month for six months;
- GBP£50,000 (approximately \$81,000) when we are in a position to drawdown funds in order to commence the development and construction (the "Financial Close") of our 49MW biomass power plant at Sutton Bridge, Lincolnshire (the "Project");
- options on the Financial Close of the completion of the Project to purchase 10,000 common shares in our company at \$2 per share; and
- on the Financial Close of the Project, 20,000 common shares of our company from PGG.

In addition to the above compensation, we agreed to compensate Mr. Williams with commissions of:

- 10%, 8% and 6% for the first, second and third years, respectively, for Envi emissions control equipment sales on any license fees generated;
- 3% of net sales for Envi emissions control equipment sales that are direct sales (with no third party commissions);
- 1% of net sales of any for Envi emissions control equipment sales from third party agents;
- 5% of any financial equity raised for our company prior to the close of the Project;
- 0.25% of any debt introduced for the Project;
- 0.5% of any financial equity introduced for the Project;
- 10%, 6%, 4% and 2% for years 1, 2, 3 and thereafter, respectively, of any heat off-take sales related to the Project entered into before December 31, 2013;
- 5%, 3% and 2% for years 1, 2 and thereafter, respectively, of any heat off-take sales related to the Project entered into on or after December 31, 2013; and
- 0.25% and 0.2% for years 1 and 2, respectively, of power purchase agreements.

Mr. Williams resigned effective April 23, 2014 and was compensated the equivalent of \$13,918 by our company during the year ended March 31, 2014 on the basis of GBP£450 (approximately US\$730) per day. Mr. Williams did not receive any other incentive amounts or commissions under the agreement.

Effective October 31, 2013, we entered into a private placement agreement. Pursuant to the agreement, we issued 18,750 common shares in our capital stock at a purchase price of \$4.00 per share, for total proceeds of \$75,000.

Effective December 19, 2013, we entered into private placement agreements with nine subscribers. Pursuant to the agreements, we issued an aggregate of 262,500 common shares in our capital stock at a purchase price of \$3.20 per share, for total proceeds of \$840,000.

On December 18, 2013, we announced that our company has engaged BlueMount Capital to spearhead the development of its proprietary emission control technologies, ENVI-Clean™ and ENVI-Pure™, in the People's Republic of China ("PRC"). In addition to corporate finance advisory services both within and outside China, BlueMount offers a tailored service to clients wishing to enter the PRC market with a particular emphasis on companies that own proprietary technology, intellectual property and expertise. To that end, BlueMount provides a comprehensive suite of services to enhance the effectiveness and long-term sustainability of foreign brands entering the PRC market via: Our company's strategic objective is to establish an operating presence in China with established local partners and rapidly rollout its technologies.

On December 27, 2013, we entered into and closed share exchange agreements with certain shareholders of EnviroTechnologies. Pursuant to the terms of the share exchange agreements, we acquired 130,000 issued and outstanding common shares of EnviroTechnologies from the shareholders in exchange for shares of common stock of our company on a 1 for 10 basis. On December 27, 2013, we issued an aggregate of 13,000 common shares to the shareholders of EnviroTechnologies.

On January 27, 2014, we entered into an agreement with Pöyry Management Consulting (UK) Limited. Pursuant to the agreement, Pöyry is to provide consulting services to us. Our company has agreed to compensate Pöyry a minimum of £5,000 (approximately \$ 8,293) as consulting fees for the first year of the agreement and a variable hourly rate as set out in the agreement.

Effective March 10, 2014, we entered into a private placement agreement with one subscriber. Pursuant to the agreement with the subscriber, we agreed to the issuance of an aggregate of 125,000 common shares in our capital stock at a purchase price of \$4.00 per share, for total proceeds of \$500,000.

On May 27, 2014, we entered into a \$200,000 convertible debenture with Intrawest Overseas Limited. Under the terms of the debenture, the amount is unsecured, bears interest at 10% per annum, and is due on May 27, 2015. Pursuant to the agreement, should any portion of loan remain outstanding past maturity the interest will increase to 15% per annum. The note is convertible into shares of common stock 180 days after the date of issuance (November 27, 2014) until maturity at a conversion rate of 75% of the average offer price of our company's common stock for the 45 days ending one trading day prior to the date the conversion notice is sent by the holder to our company.

Our company analyzed the conversion option under ASC 815, "Accounting for Derivative Instruments and Hedging Activities", and determined that the conversion feature should be classified as a liability and recorded at fair value due to there being no explicit limit to the number of shares to be delivered upon settlement of the conversion option. In accordance with ASC 815, our company recognized the intrinsic value of the embedded beneficial conversion feature of \$33,922. On November 27, 2014, the note became convertible resulting in our company recording a derivative liability of \$33,922 with a corresponding adjustment to loss on change in fair value of derivative liabilities.

On June 12, 2014, we entered into a \$100,000 convertible debenture with Gerstle Consulting Pty Limited. Under the terms of the debenture, the amount is unsecured, bears interest at 10% per annum, and is due on June 12, 2015. Pursuant to the agreement, should any portion of loan remain outstanding past maturity the interest will increase to 15% per annum. The note is convertible into shares of common stock 180 days after the date of issuance (December 12, 2014) until maturity at a conversion rate of 75% of the average closing bid prices of our company's common stock for the 45 days ending one trading day prior to the date the conversion notice is sent by the holder to our company.

Our company analyzed the conversion option under ASC 815, "Accounting for Derivative Instruments and Hedging Activities", and determined that the conversion feature should be classified as a liability and recorded at fair value due to there being no explicit limit to the number of shares to be delivered upon settlement of the conversion option. In accordance with ASC 815, our company recognized the intrinsic value of the embedded beneficial conversion feature of \$9,793. On December 12, 2014, the note became convertible resulting in our company recording a derivative liability of \$9,793 with a corresponding adjustment to loss on change in fair value of derivative liabilities.

On June 30, 2015, through our wholly owned subsidiary, Pacific Green Energy Parks Limited, we purchased all of the issued and outstanding shares in Pacific Green Technologies Asia Limited for \$1.00 from Alexander Shead.

We entered into an agreement dated July 20, 2015 with Mr. Alexander Shead. Pursuant to this agreement, Mr. Shead has agreed to serve as a director of our company. As a director of our company, Mr. Shead shall be compensated \$1,000 for every calendar month of the term of the agreement. The term of the agreement is for 12 months. On July 20, 2015, we appointed Mr. Shead as a director of our company.

On September 22, 2015, our company entered into a consulting agreement (the "**Agreement**") with Midam Ventures, LLC ("**Midam**") wherein Midam will provide investor relations and business advisory services to us from September 23, 2015 to March 23, 2016. Any compensation described in the Agreement shall be deemed earned and vested by Midam even in the case of early termination of the Agreement.

Pursuant to the terms of the Agreement, we will to pay \$30,000 in cash and 200,000 common restricted shares of our company to Midam. Effective October 20, 2015, we issued all of the shares pursuant to an exemption from registration relying on the provisions of Rule 506 of Regulation D promulgated under the *Securities Act of 1933*, as amended.

On October 24, 2015, our company entered into a marketing and consulting agreement with Red Rock Marketing Media, Inc. ("**Red Rock**") wherein Red Rock will provide investor relations and business advisory services to us for a period of 40 business days starting on or before the 10 business days after Red Rock receives compensation from our company. Pursuant to the terms of the Agreement, we will to pay \$100,000 in cash by October 29, 2015.

On October 27, 2015, our company entered into a loan agreement with a significant shareholder for proceeds of approximately \$4,231. The loan is unsecured, bears an interest rate of US Prime Rate plus 4%, and is due on demand.

On November 10, 2015, we issued a convertible note (the “**Note**”) to Tangiers Investment Group, LLC (“**Tangiers**”) in exchange for an aggregate of \$100,000 from Tangiers. The Note is for the aggregate sum of \$110,000 with 10% interest as an original issue discount and convertible into our common shares of (the “**Shares**”) at a price of equal to the lower of: (a) \$.40 per common share of our company or (b) 60% of the lowest trading price of our common stock during the 20 consecutive trading days prior to the date on which the holder of the Note elects to convert all or part of the Note.

On November 17, 2015, Pacific Green Technologies China Limited, a wholly-owned subsidiary of our company, entered into a commercial joint venture agreement with PowerChina SPEM Company Limited (“**PowerChina**”) wherein PowerChina would receive and process orders from our company for customers, and manufacture and install products as an engineering procurement construction process. In return, our company agreed to design the product and provide a technology license and technical supports to PowerChina. During the Agreement, we will provide PowerChina with a non-transferrable right and license to use Technology to manufacture and install our product within the Peoples’ Republic of China.

Upon receiving each order from us, PowerChina and we shall submit to each other the respective estimated budgets. For each project, after receipt of the revenue from the relevant customer, the budgets of our company and PowerChina shall be deducted and reimbursed from the revenue proportionally. We have agreed to share the gross profit pursuant to an even split of 50% to PowerChina and 50% to our company.

### **Competition**

We face competition from various companies involved in the environmental technology industries and specifically companies involved in filtering of pollutants.

Many of our competitors have longer operating histories, better brand recognition and greater financial resources than we do. In order for us to successfully compete in our industry we will need to:

- establish our product’s competitive advantage with customers;
- develop a comprehensive marketing system; and
- increase our financial resources.

However, there can be no assurance that even if we do these things, we will be able to compete effectively with the other companies in our industry.

As we are a newly-established company, we face the same problems as other new companies starting up in an industry, such as lack of available funds. Our competitors may be substantially larger and better funded than us, and have significantly longer histories of research, operation and development than us. In addition, they may be able to provide more competitive products than we can and generally be able to respond more quickly to new or emerging technologies and changes in legislation and regulations relating to the industry. Additionally, our competitors may devote greater resources to the development, promotion and sale of their products or services than we do. Increased competition could also result in loss of key personnel, reduced margins or loss of market share, any of which could harm our business.

### **Research and Development Expenditures**

We have not incurred any research expenditures over the past two fiscal years.

### **Intellectual Property**

We do not own, either legally or beneficially, any patent or trademark, except for the foregoing.

We now own the proprietary emission abatement systems, currently known as ENVI-Clean™, ENVI-Pure™, for removing acid gases, particulate matter, dioxins, VOCs and other regulated hazardous air pollutants from the flue gases produced by the combustion of coal, biomass, municipal solid waste, diesel and other fuels, and ENVI-SEA™, scrubber that can be applied to diesel exhaust emissions that require sulphur and particulate matter abatement, previously owned or controlled by the Debtors, and includes, without limitation, all developments, improvements, and derivative works based upon or incorporating the Technology, all work product created by the Debtors, and all intellectual property in the foregoing.

The ENVI-Clean™ system has protected intellectual property rights throughout most of the world. Its technology is protected by Patent Cooperation Treaty (PCT) patent application no. PCT/CA210/000988 filed June 25, 2010 with a priority filing date of June 25, 2009. The International Preliminary Report on Patentability for this PCT application considered all patent claims of the application to be patentable. EnviroTechnologies has pending national or regional phase patent applications claiming priority from PCT/CA210/000988 covering 127 countries. Once patents issue, patent rights in this technology will generally endure until June 25, 2030.

Further, we own the rights to the US provisional patent application no. US 61/614696 for the integrated wet scrubbing system. Additionally, we own the rights to US provisional patent application no. US 61/645874 for the flooded wet scrubbing head patent.

### **Identification of Certain Significant Employees**

Currently, we do not have any employees. Other than as set out below, we have not entered into any consulting or employment agreements with any of our other directors.

Effective December 18, 2012, we entered into a non-executive director agreement with Dr. Neil Carmichael, wherein Dr. Carmichael received compensation of \$1,000 for the term of the agreement and shall be granted options to purchase up to 62,500 shares of common stock at an exercise price of \$0.01 per share of common stock. The options will terminate the earlier of 24 months, or upon the termination of the agreement and Dr. Carmichael's engagement with our company. As of the date of this annual report, the options to Dr. Carmichael have been granted and have not yet been exercised.

On September 26, 2013, we entered into an agreement with Andrew Jolly, wherein Dr. Jolly agreed to serve as a director of our company. Pursuant to the agreement, our company is to compensate Dr. Jolly for serving as a director of our company at GBP£2,000 (approximately \$3,235) per calendar month. Effective October 1, 2013, we appointed Dr. Jolly as a director of our company.

On October 22, 2013, we entered into an agreement with Mr. Chris Williams, wherein Mr. Williams agreed to serve as business development director of our company effective December 5, 2013. As business development director of our company, Mr. Williams was to focus on developing potential new business opportunities and generating sales from our existing assets. Mr. Williams resigned effective April 23, 2014.

Our directors, executive officers and certain contracted individuals play an important role in the running of our company. We do not expect any material changes in the number of employees over the next 12 month period. We do and will continue to outsource contract employment as needed.

We engage contractors from time to time to consult with us on specific corporate affairs or to perform specific tasks in connection with our operations.

### **Government Regulations**

Some aspects of our intended operations will be subject to a variety of federal, provincial, state and local laws, rules and regulations in North America and worldwide relating to, among other things, worker safety and the use, storage, discharge and disposal of environmentally sensitive materials. For example, we are subject to the Resource Conservation Recovery Act ("RCRA"), the principal federal legislation regulating hazardous waste generation, management and disposal.

Under some of the laws regulating the use, storage, discharge and disposal of environmentally sensitive materials, an owner or lessee of real estate may be liable for the costs of removing or remediating certain hazardous or toxic substances located on or in, or emanating from, such property, as well as related costs of investigation and property damage. Laws of this nature often impose liability without regard to whether the owner or lessee knew of, or was responsible for, the presence of the hazardous or toxic substances. These laws and regulations may require the removal or remediation of pollutants and may impose civil and criminal penalties for violations. Some of the laws and regulations authorize the recovery of natural resource damages by the government, injunctive relief and the imposition of stop, control, remediation and abandonment orders. The costs arising from compliance with environmental and natural resource laws and regulations may increase operating costs for both us and our potential customers. We are also subject to safety policies of jurisdictional-specific Workers Compensation Boards and similar agencies regulating the health and safety of workers.

We are not aware of any material violations of environmental permits, licenses or approvals issued with respect to our operations. We expect to comply with all applicable laws, rules and regulations relating to our intended business. At this time, we do not anticipate any material capital expenditures to comply with environmental or various regulations and requirements.

While our intended projects or business activities have been designed to produce environmentally friendly green energy or other alternative products for which no specific regulatory barriers exist, any regulatory changes that impose additional restrictions or requirements on us or on our potential customers could adversely affect us by increasing our operating costs and decreasing potential demand for our technologies, products or services, which could have a material adverse effect on our results of operations.

### **Subsidiaries**

Both Sichel Limited and Pacific Green Group Limited are wholly owned subsidiaries of the Hookipia Trust. Pacific Green Group Limited's wholly owned subsidiary was Pacific Green Technologies Limited. As a result, we acquired Pacific Green Technologies Limited from Pacific Green Group Limited. Sichel is a significant shareholder of our company, and also provides us with consulting services pursuant to a consulting agreement. The sole director of Sichel is also the sole director of Pacific Green Group Limited. Further, PGG is a significant shareholder of EnviroTechnologies.

Our company's wholly owned subsidiaries are Pacific Green Technologies Marine Limited (formerly Pacific Green Technologies Limited), a United Kingdom corporation, Pacific Green Technologies International Limited (formerly Pacific Green Energy Parks Limited), a British Virgin Islands corporation, and its wholly owned subsidiaries, Energy Park Sutton Bridge, a United Kingdom corporation, and Pacific Green Technologies Asia Limited, a Hong Kong corporation, and its wholly owned subsidiary, Pacific Green Technologies China Limited, a Hong Kong corporation.

### **REPORTS TO SECURITY HOLDERS**

We are required to file annual, quarterly and current reports, proxy statements and other information with the Securities and Exchange Commission and our filings are available to the public over the internet at the Securities and Exchange Commission's website at <http://www.sec.gov>. The public may read and copy any materials filed by us with the Securities and Exchange Commission at the Securities and Exchange Commission's Public Reference Room at 100 F Street N.E. Washington D.C. 20549. The public may obtain information on the operation of the Public Reference Room by calling the Securities and Exchange Commission at 1-800-732-0330. The SEC also maintains an Internet site that contains reports, proxy and formation statements, and other information regarding issuers that file electronically with the SEC, at <http://www.sec.gov>.

### **Employees**

As of March 31, 2016, we did not have any full-time or part-time employees. Our president, treasurer, secretary and director, Neil Carmichael, works as a part-time consultant and devotes approximately 10 hours per week to our business. Our director, Jordan Starkman, works as a part-time consultant and devotes approximately 20 hours per month to our business. Our director, Andrew Jolly, works as a part-time consultant to our company and devotes his time to our business on an as needed basis. Our former director, Chris Williams, worked as a part-time consultant and devoted approximately 1 hour per week to our business. Mr. Williams resigned on April 23, 2014. If our financial position permits, as required by our business, we may enlist certain individuals on a full or part-time salaried basis to assist with marketing, advertising, administration and data management for our business.

### **Item 1A. Risk Factors**

#### **Risks Related to our Business**

*We have a limited operating history with significant losses and expect losses to continue for the foreseeable future.*

We have yet to establish any history of profitable operations. We incurred a net loss of \$60,130,794 for the period from April 5, 2011 (inception) to March 31, 2016. We had a net loss of \$7,446,232 for the year ended March 31, 2016. We have not generated any revenues since our inception. We expect that our revenues will not be sufficient to sustain our operations for the foreseeable future. Our profitability will depend on our ability to successfully market and sell the ENVI-Clean™ system and there can be no assurance that we will be able to do so.



*There is doubt about our ability to continue as a going concern due to recurring losses from operations, accumulated deficit and insufficient cash resources to meet our business objectives, all of which means that we may not be able to continue operations.*

Our independent auditors have added an explanatory paragraph to their audit opinion issued in connection with the consolidated financial statements for the years ended March 31, 2016 and 2015, respectively, with respect to their doubt about our ability to continue as a going concern. As discussed in Note 1 to our consolidated financial statements for the year ended March 31, 2016, we have incurred operating losses since inception, and our cash resources are insufficient to meet our planned business objectives, which together raises substantial doubt about our ability to continue as a going concern.

*We may not be able to secure additional financing to meet our future capital needs due to changes in general economic conditions.*

We anticipate needing significant capital to develop our sales force and effective market the ENVI-Clean™ system. We may use capital more rapidly than currently anticipated and incur higher operating expenses than currently expected, and we may be required to depend on external financing to satisfy our operating and capital needs. We may need new or additional financing in the future to conduct our operations or expand our business. Any sustained weakness in the general economic conditions and/or financial markets in the United States or globally could adversely affect our ability to raise capital on favorable terms or at all. From time to time we have relied, and may also rely in the future, on access to financial markets as a source of liquidity to satisfy working capital requirements and for general corporate purposes. We may be unable to secure debt or equity financing on terms acceptable to us, or at all, at the time when we need such funding. If we do raise funds by issuing additional equity or convertible debt securities, the ownership percentages of existing stockholders would be reduced, and the securities that we issue may have rights, preferences or privileges senior to those of the holders of our common stock or may be issued at a discount to the market price of our common stock which would result in dilution to our existing stockholders. If we raise additional funds by issuing debt, we may be subject to debt covenants, which could place limitations on our operations including our ability to declare and pay dividends. Our inability to raise additional funds on a timely basis would make it difficult for us to achieve our business objectives and would have a negative impact on our business, financial condition and results of operations.

*We are a development stage company and we may not be successful in marketing the ENVI-Clean™ system and the value of your investment could decline.*

We are a development stage company with no substantial tangible assets in a highly competitive industry. We have little operating history, no customers, and no revenues. This makes it difficult to evaluate our future performance and prospects. Our prospects must be considered in light of the risks, expenses, delays and difficulties frequently encountered in establishing a new business in an emerging and evolving industry, including the following factors:

- our business model and strategy are still evolving and are continually being reviewed and revised;
- we may not be able to raise the capital required to develop our initial client base and reputation; and
- we may not be able to successfully develop our planned products and services.

We cannot be sure that we will be successful in meeting these challenges and addressing these risks and uncertainties. If we are unable to do so, our business will not be successful and the value of your investment in us will decline.

*Our business is subject to environmental and consumer protection legislation and any changes in such legislation could prevent us from becoming profitable.*

The energy production and technology industries are subject to many laws and regulations which govern the protection of the environment, quality control standards, health and safety requirements, and the management, transportation and disposal of hazardous substances and other waste. Environmental laws and regulations may require removal or remediation of pollutants and may impose civil and criminal penalties for violations. Some environmental laws and regulations authorize the recovery of natural resource damages by the government, injunctive relief and the imposition of stop, control, remediation and abandonment orders. Similarly, consumer protection laws impose quality control standards on products marketed to the public and prohibit the distribution and marketing of products not meeting those standards.

The costs arising from compliance with environmental and consumer protection laws and regulations may increase operating costs for both us and our potential customers. Any regulatory changes that impose additional environmental restrictions or quality control requirements on us or on our potential customers could adversely affect us through increased operating costs and potential decreased demand for our services, which could prevent us from becoming profitable.

*The development and expansion of our business through acquisitions, joint ventures, and other strategic transactions may create risks that may reduce the benefits we anticipate from these strategic alliances and may prevent us from achieving or sustaining profitability.*

We intend to enter into technology acquisition and licensing agreements and strategic alliances such as joint ventures or partnerships in order to develop and commercialize our proposed technologies and services, and to increase our competitiveness. We currently do not have any commitments or agreements regarding acquisitions, joint ventures or other strategic alliances. Our management is unable to predict whether or when we will secure any such commitments or agreements, or whether such commitments or agreements will be secured on favorable terms and conditions.

Our ability to continue or expand our operations through acquisitions, joint ventures or other strategic alliances depends on many factors, including our ability to identify acquisitions, joint ventures, or partnerships, or access capital markets on acceptable terms. Even if we are able to identify strategic alliance targets, we may be unable to obtain the necessary financing to complete these transactions and could financially overextend ourselves.

Acquisitions, joint ventures or other strategic transactions may present financial, managerial and operational challenges, including diversion of management attention from existing business and difficulties in integrating operations and personnel. Acquisitions or other strategic alliances also pose the risk that we may be exposed to successor liability relating to prior actions involving a predecessor company, or contingent liabilities incurred before a strategic transaction. Due diligence conducted in connection with an acquisition, and any contractual guarantees or indemnities that we receive from sellers of acquired companies, may not be sufficient to protect us from, or compensate us for, actual liabilities. Liabilities associated with an acquisition or a strategic transaction could adversely affect our business and financial performance and reduce the benefits of the acquisition or strategic transaction. Any failure to integrate new businesses or manage any new alliances successfully could adversely affect our business and financial performance and prevent us from achieving profitability.

*Our sole officer will only spend a modest portion of his available time managing our company. As a result, our success depends on the continuing efforts of other members of our senior management team and employees and the loss of the services of such key personnel could result in a disruption of operations which could result in reduced revenues.*

We are dependent upon our officer for execution of our business plan. However, our sole officer, Neil Carmichael, will only spend a modest amount of his time in managing our company. As a result, our future success depends heavily upon the continuing services of the other members of our senior management team. If one or more of such other of our senior executives or other key personnel are unable or unwilling to continue in their present positions, we may not be able to replace them easily or at all, and our business may be disrupted and our financial condition and results of operations may be materially and adversely affected. Competition for senior management and key personnel is intense, the pool of qualified candidates is very limited, and we may not be able to retain the services of our senior executives or key personnel, or attract and retain high-quality senior executives or key personnel in the future. We do not currently maintain key man insurance on our senior managers. The loss of the services of our senior management team and employees could result in a disruption of operations which could result in reduced revenues.

*We assumed debt as a result of the assignment agreement that we may not be able to repay, resulting in possible default and/or substantial dilution to our shareholders.*

The assignment agreement was partly funded through a promissory note of \$5 million as set out in this document. There is a risk that we may not be able to repay the promissory note when it is due on maturity. In addition, any failure by us to repay the promissory note may result in PGG converting the amount outstanding into new shares of our company's common stock which would have the effect of diluting existing shareholders.

*We are at risk that the ENVI-Clean™ system will not perform to expectations.*

As at the date of this annual report, the ENVI-Clean™ system has been tested to satisfactory requirements but there is no guarantee that the ENVI-Clean™ system will continue to perform satisfactorily in the future which would damage our prospects following the Assignment.

*The market for alternative energy products, technologies or services is emerging and rapidly evolving and its future success is uncertain. Insufficient demand for the ENVI-Clean™ system would prevent us from achieving or sustaining profitability.*

It is possible that we may spend large sums of money to bring the ENVI-Clean™ system to the market, but demand may not develop or may develop more slowly than we anticipate.

Our future success is dependent on EnviroTechnologies and its technologies in regards to:

- (a) its ability to quickly react to technological innovations;
- (b) the cost-effectiveness of its technologies;
- (c) the performance and reliability of alternative energy products and services that it develops;
- (d) its ability to formalize marketing relationships or secure commitments for our technologies, products and services;
- (e) realization of sufficient funding to support our and EnviroTechnologies marketing and business development plans; and
- (f) availability of government incentives for the development or use of any products and services that we or EnviroTechnologies develop.

We may be unable to develop widespread commercial markets or obtain sufficient demand or broad acceptance for the EnviroTechnologies alternative energy products or technologies or services. We may be unable to achieve or sustain profitability.

*Competition within the environment sustainability industry may prevent us from becoming profitable.*

The alternative energies industry is competitive and fragmented and includes numerous small companies capable of competing effectively in the market we target as well as several large companies that possess substantially greater financial and other resources than we do. Larger competitors' greater resources could allow those competitors to compete more effectively than we can with the EnviroTechnologies technology. A number of competitors have developed more mature businesses than EnviroTechnologies has and have successfully built their names in the international alternative energy markets. These various competitors may be able to offer products, sustainability technologies or services more competitively priced and more widely available than EnviroTechnologies and also may have greater resources to create or develop new technologies and products than EnviroTechnologies. Failure to compete either in the alternative energy industry may prevent us from becoming profitable, and thus you may lose your entire investment.

*We are at risk of EnviroTechnologies not being able to manufacture the ENVI-Clean™ system in accordance with contractual terms.*

All contracts which we secure for the sale of ENVI-Clean™ system between EnviroTechnologies and a third party will require that EnviroTechnologies supplies a functioning emission control system. There is a risk that EnviroTechnologies is unable to manufacture and supply such a system in accordance with the terms of the contract. Any failure by EnviroTechnologies to perform its obligations under any such contract may have a detrimental impact on our financial standing and reputation.

#### **Risks Related to our Stockholders and Shares of Common Stock**

*The continued sale of our equity securities will dilute the ownership percentage of our existing stockholders and may decrease the market price for our common stock.*

Given our lack of revenues and the doubtful prospect that we will earn significant revenues in the next several years, we will require additional financing of at least \$1,070,000 for the next 12 months, which will require us to issue additional equity securities as we only had \$40,108 cash on hand as of March 31, 2016. We expect to continue our efforts to acquire financing to fund our planned development and expansion activities, which will result in dilution to our existing stockholders. In short, our continued need to sell equity will result in reduced percentage ownership interests for all of our investors, which may decrease the market price for our common stock.

*We do not intend to pay dividends and there will thus be fewer ways in which you are able to make a gain on your investment.*

We have never paid dividends and do not intend to pay any dividends for the foreseeable future. To the extent that we may require additional funding currently not provided for in our financing plan, our funding sources may prohibit the declaration of dividends. Because we do not intend to pay dividends, any gain on your investment will need to result from an appreciation in the price of our common stock. There will therefore be fewer ways in which you are able to make a gain on your investment. In the future when we do intend to pay dividend, we will formalize a dividend policy.

*Because the SEC imposes additional sales practice requirements on brokers who deal in shares of penny stocks, some brokers may be unwilling to trade our securities. This means that you may have difficulty reselling your shares, which may cause the value of your investment to decline.*

Our shares are classified as penny stocks and are covered by Section 15(g) of the Securities Exchange Act of 1934 (the “Exchange Act”) which imposes additional sales practice requirements on brokers-dealers who sell our securities in this offering or in the aftermarket. For sales of our securities, broker-dealers must make a special suitability determination and receive a written agreement prior from you to making a sale on your behalf. Because of the imposition of the foregoing additional sales practices, it is possible that broker-dealers will not want to make a market in our common stock. This could prevent you from reselling your shares and may cause the value of your investment to decline.

*Financial Industry Regulatory Authority (FINRA) sales practice requirements may limit your ability to buy and sell our common stock, which could depress the price of our shares.*

FINRA rules require broker-dealers to have reasonable grounds for believing that an investment is suitable for a customer before recommending that investment to the customer. Prior to recommending speculative low-priced securities to their non-institutional customers, broker-dealers must make reasonable efforts to obtain information about the customer’s financial status, tax status and investment objectives, among other things. Under interpretations of these rules, FINRA believes that there is a high probability such speculative low-priced securities will not be suitable for at least some customers. Thus, FINRA requirements make it more difficult for broker-dealers to recommend that their customers buy our common stock, which may limit your ability to buy and sell our shares, have an adverse effect on the market for our shares, and thereby depress our share price.

*We are an “emerging growth company” under the JOBS Act of 2012, and we cannot be certain if the reduced disclosure requirements applicable to emerging growth companies will make our common stock less attractive to investors.*

We are an “emerging growth company,” as defined in the Jumpstart Our Business Startups Act of 2012 (“JOBS Act”), and we may take advantage of certain exemptions from various reporting requirements that are applicable to other public companies that are not “emerging growth companies” including, but not limited to, not being required to comply with the auditor attestation requirements of section 404 of the Sarbanes-Oxley Act, reduced disclosure obligations regarding executive compensation in our periodic reports and proxy statements, and exemptions from the requirements of holding a nonbinding advisory vote on executive compensation and shareholder approval of any golden parachute payments not previously approved. We cannot predict if investors will find our common stock less attractive because we may rely on these exemptions. If some investors find our common stock less attractive as a result, there may be a less active trading market for our common stock and our stock price may be more volatile.

We will remain an “emerging growth company” for up to five years, although we will lose that status sooner if our revenues exceed \$1 billion, if we issue more than \$1 billion in non-convertible debt in a three year period, or if the market value of our common stock that is held by non-affiliates exceeds \$700 million as of any May 30.

*Our status as an “emerging growth company” under the JOBS Act of 2012 may make it more difficult to raise capital as and when we need it.*

Because of the exemptions from various reporting requirements provided to us as an “emerging growth company” we may be less attractive to investors and it may be difficult for us to raise additional capital as and when we need it. Investors may be unable to compare our business with other companies in our industry if they believe that our reporting is not as transparent as other companies in our industry. If we are unable to raise additional capital as and when we need it, our financial condition and results of operations may be materially and adversely affected.

#### **Item 1B. Unresolved Staff Comments**

As a “smaller reporting company”, we are not required to provide the information required by this Item.

#### **Item 2. Properties**

Our registered business address for correspondence is 5205 Prospect Road, Suite 135-226, San Jose, CA 95129. We pay rent of \$200 per month for our business office space. Our telephone number is (408) 538-3373.

### Item 3. Legal Proceedings

Except for below, we know of no material, existing or pending legal proceedings against our company, nor are we involved as a plaintiff in any material proceeding or pending litigation. There are no proceedings in which any of our directors, officers or affiliates, or any registered beneficial shareholder, is an adverse party or has a material interest adverse to our interest.

On November 14, 2013, a shareholder holding one common share in our company (the "Plaintiff") commenced an action against us, as a nominal defendant, and PGG for recovery of short-swing profits (the "Action") under section 16(b) of the Securities Exchange Act of 1934, as amended ("Section 16(b)"). The Plaintiff alleges that PGG, a shareholder of our company of more than ten percent, profited from the purchase and sale of our stock within a period of less than six months.

PGG disposed of:

1. 37,778 shares of common stock at \$4.00 per share on July 22, 2013;
2. 62,600 shares of common stock at \$3.00 per share on August 9, 2013;
3. 16,000 shares of common stock at \$4.00 per share on September 17, 2013; and
4. 210,834 shares of common stock at \$3.00 per share on September 24, 2013

On August 27, 2013, PGG acquired 2,237,929 shares at a deemed value of \$0.001, being our common share par value, pursuant to a share exchange with shareholders of EnviroTechnologies. The Action states that, pursuant to Section 16(b), the alleged total short-swing profit is \$1,035,086.79 and must be disgorged to our company.

As our company declined to pursue a claim against PGG under Section 16(b), the Action was brought on behalf of our company by the Plaintiff. This action was commenced in the United States District Court in the Southern District of New York. On January 12, 2016, a Settlement Agreement was reached between the parties that requires PGG to pay PGT and further, PGT to pay McVety counsel \$325,000 in tranches of \$150,000 within 60 days of the agreement being fully executed, \$50,000 within 120 days of the settlement and \$125,000 within 7 months of the settlement. On August 18, 2016 the US District Court, Southern District of New York dismissed the action upon notification by the plaintiff's counsel that the final payment had been made.

### Item 4. Mine Safety Disclosures

Not applicable.

## PART II

### Item 5. Market for Registrant's Common Equity, Related Stockholder Matters and Issuer Purchases of Equity Securities

Our common shares are quoted on the OTCQB under the symbol "PGTK", but trade infrequently. Our common shares are not listed on NASDAQ and we do not currently have any intention to list any of our securities on that market.

The high and low bid prices of our common stock for the periods indicated below are as follows:

OTCQB <sup>(1)</sup>		
Quarter Ended	High	Low
March 31, 2016	\$ 3.00	\$ 0.80
December 31, 2015	\$ 1.45	\$ 0.20
September 30, 2015	\$ 1.10	\$ 0.25
June 30, 2015	\$ 1.30	\$ 0.70
March 31, 2015	\$ 1.15	\$ 0.16
December 31, 2014	\$ 1.10	\$ 0.25
September 30, 2014	\$ 2.05	\$ 1.07
June 30, 2014	\$ 6.90	\$ 2.01
March 31, 2014	\$ 7.25	\$ 4.25

1. Over-the-counter market quotations reflect inter-dealer prices without retail mark-up, mark-down or commission, and may not represent actual transactions. Our shares did not begin trading until June 14, 2012. Our transfer agent is American Stock Transfer & Trust Company, 6201 15th Avenue, Brooklyn, New York, 11219; telephone number (718) 921-8200; facsimile number (718) 765-8711.

As of August 12, 2016, there were 196 holders of record of our common stock. As of such date, 23,908,576 of our common stock were issued and outstanding.

#### **Dividends**

We have not paid any cash dividends to date and do not anticipate or contemplate paying dividends in the foreseeable future. It is the present intention of management to utilize all available funds for the development of our business.

#### **Securities Authorized for Issuance under Equity Compensation Plans**

Effective December 18, 2012, we entered into a non-executive director agreement with Dr. Neil Carmichael, wherein Dr. Carmichael shall be granted options to purchase up to 62,500 shares of common stock at an exercise price of \$0.01 per share of common stock. The options will terminate the earlier of 24 months, or upon the termination of the agreement and Dr. Carmichael's engagement with our company. As of the date of this annual report, the options to Dr. Carmichael have been granted but not yet exercised.

#### **Recent Sales of Unregistered Securities; Use of Proceeds from Registered Securities**

On May 4, 2015, we issued 1,058,317 shares of common stock with a fair value of \$1,068,900 pursuant to a settlement agreement for the extinguishment of \$200,000 in principal, \$18,888 in accrued interest, and the \$1,012,876 derivative liability relating to the May 27, 2014 convertible debenture. The fair value of the common stock was determined based on the closing price of our company's common stock. This transaction resulted in a gain on extinguishment of debt of \$162,864.

On May 13, 2015, we issued 459,418 shares of common stock with a fair value of \$537,519 pursuant to a settlement agreement for the extinguishment of \$100,000 in principal, \$7,795 in accrued interest, and the \$438,361 derivative liability relating to the June 12, 2014 convertible debenture. The fair value of the common stock was determined based on the closing price of our company's common stock. This transaction resulted in a gain on extinguishment of debt of \$8,637.

On August 10, 2015, we issued 50,000 shares of common stock to a company controlled by a director of our company relating to a non-brokered private placement on May 20, 2015 at a price of \$0.50 per share for proceeds of \$25,000. In consideration for the share subscription, our company granted the subscriber an option to purchase a minimum of \$93,750 to a maximum of \$125,000 of shares of common stock. The option vests upon our company entering into a binding agreement for the sale or license of its ENVI-Clean or ENVI-Pure emission control technology system (the "**Option Event**") and must be exercised within 28 days of the Option Event. The option expires on May 20, 2017 and is exercisable at a conversion rate of 75% of the average closing bid prices of our company's common stock for the 10 trading days prior to the Option Event and the 10 trading days after the Option Event. The exercise price shall not be less than \$1.00 per share and not greater than \$2.50 per share. The option vested on November 17, 2015 when the Company entered into a commercial joint venture agreement.

On August 10, 2015, we issued 550,000 shares of common stock relating to a non-brokered private placement on May 26, 2015 at a price of \$0.50 per share for proceeds of \$275,000. In consideration for the share subscription, our company granted the subscriber an option to purchase a minimum of \$1,031,250 to a maximum of \$1,375,000 of shares of common stock. The option vests upon our company entering into a binding agreement for the sale or license of its ENVI-Clean or ENVI-Pure emission control technology system and must be exercised within 28 days of the Option Event. The option expires on May 22, 2017 and is exercisable at a conversion rate of 75% of the average closing bid prices of our company's common stock for the 10 trading days prior to the Option Event and the 10 trading days post the Option Event. The exercise price shall not be less than \$1.00 per share and not greater than \$2.50 per share. The option vested on November 17, 2015 when the Company entered into a commercial joint venture agreement.

On August 10, 2015, we issued 100,000 shares of common stock relating to a non-brokered private placement on June 6, 2015 at a price of \$0.50 per share for proceeds of \$50,000. In consideration for the share subscription, our company granted the subscriber an option to purchase an additional \$250,000 of shares of common stock at \$1.50 per share, expiring on June 6, 2017. The option vests upon our company entering into a binding agreement for the sale or license of its ENVI-Clean or ENVI-Pure emission control technology system and must be exercised within 21 days of the Option Event. The option vested on November 17, 2015 when the Company entered into a commercial joint venture agreement.

On August 10, 2015, we issued 600,000 shares of common stock relating to a non-brokered private placement on June 10, 2015 at a price of \$0.50 per share for proceeds of \$300,000. In consideration for the share subscription, our company granted the subscriber an option to purchase an additional \$1,500,000 of shares of common stock at \$1.50 per share, expiring on June 6, 2017. The option vests upon our company entering into a binding agreement for the sale or license of its ENVI-Clean or ENVI-Pure emission control technology system and must be exercised within 21 days of the Option Event. The option vested on November 17, 2015 when the Company entered into a commercial joint venture agreement.

On October 2, 2015, we issued 960,017 shares of common stock with a fair value of \$3,840,068 (included in common stock issuable as at March 31, 2015) in a share exchange agreement with the shareholders of Enviro for the acquisition of 9,600,167 shares of common stock which were subsequently returned to Enviro pursuant to the Assignment of Assets agreement dated May 15, 2013.

On September 22, 2015, our company entered into a consulting agreement (the “**Agreement**”) with Midam Ventures, LLC (“**Midam**”) wherein Midam will provide investor relations and business advisory services to us from September 23, 2015 to March 23, 2016. Any compensation described in the Agreement shall be deemed earned and vested by Midam even in the case of early termination of the Agreement.

Pursuant to the terms of the Agreement, we were to pay \$30,000 in cash and issue 200,000 common restricted shares of our company to Midam. Effective October 20, 2015, we issued all of the shares pursuant to an exemption from registration relying on the provisions of Rule 506 of Regulation D promulgated under the *Securities Act of 1933*, as amended.

On November 10, 2015, we issued a convertible note (the “**Note**”) to Tangiers Investment Group, LLC (“**Tangiers**”) in exchange for an aggregate of \$100,000 from Tangiers. The Note is for the aggregate sum of \$110,000 with 10% interest as an original issue discount and convertible into our common shares of (the “**Shares**”) at a price of equal to the lower of: (a) \$.40 per common share of our company or (b) 60% of the lowest trading price of our common stock during the 20 consecutive trading days prior to the date on which the holder of the Note elects to convert all or part of the Note.

On December 11, 2015, we issued 433,333 shares of common stock relating to a non-brokered private placement at a price of \$0.75 per share for proceeds of \$325,000.

On December 15, 2015, we issued 200,000 shares of common stock relating to a non-brokered private placement at a price of \$0.75 per share for proceeds of \$150,000.

On February 10, 2016, our company entered into share exchange agreements (each, an “**Agreement**”) with certain shareholders (the “**Shareholder**”) of EnviroTechnologies, Inc., a Delaware corporation (“**Enviro**”). Pursuant to the terms of the Agreements, we have agreed to acquire 21,721,414 issued and outstanding common shares of Enviro from the Shareholder in exchange for shares of common stock of our company on an one (1) for ten (10) basis. We did not issue any fractional shares of our company. In lieu of such fractional shares, the Shareholder entitled to such fractional shares had such fraction rounded up to the nearest whole number of shares of our company.

On February 10, 2016, pursuant to the Agreements, we closed on the above share exchange. We issued an aggregate of 2,172,142 unregistered and restricted common shares to three (3) non-US persons (as that term is defined in Regulation S of the Securities Act of 1933), in an offshore transaction relying on Regulation S of the Securities Act of 1933, as amended.

As at March 31, 2016, we had \$150,000 of share subscription proceeds for 150,000 shares of common stock at \$1.00 per share recorded in common stock issuable to a company controlled by a director of our company.

## **Item 6. Selected Financial Data**

As a “smaller reporting company”, we are not required to provide the information required by this Item.

## **Item 7. Management’s Discussion and Analysis of Financial Condition and Results of Operations**

The following discussion should be read in conjunction with our audited consolidated financial statements and the related notes for the years ended March 31, 2016 and 2015 that appear elsewhere in this annual report. The following discussion contains forward-looking statements that reflect our plans, estimates and beliefs. Our actual results could differ materially from those discussed in the forward looking statements. Factors that could cause or contribute to such differences include, but are not limited to those discussed below and elsewhere in this annual report, particularly in the section entitled “Risk Factors” beginning on page 19 of this annual report.

Our audited consolidated financial statements are stated in United States Dollars and are prepared in accordance with United States generally accepted accounting principles.

## Results of Operations

The following summary of our results of operations should be read in conjunction with our audited financial statements for the years ended March 31, 2016 and 2015.

Our operating expenses for the years ended March 31, 2016 and 2015 are summarized as follows:

	Year Ended March 31,	
	2016	2015
Advertising	\$ 10,000	\$ Nil
Amortization of intangible assets	\$ 868,675	\$ 868,675
Consulting fees	\$ 3,216,033	\$ 711,579
Foreign exchange gain	\$ (49,257)	\$ (521,925)
Office and miscellaneous	\$ 87,065	\$ 40,506
Professional fees	\$ 224,737	\$ 176,796
Transfer agent and filing fees	\$ 35,407	\$ 31,341
Travel	\$ 87,835	\$ 24,370
<b>Total operating expenses</b>	<b>\$ 4,480,495</b>	<b>\$ 1,331,342</b>

Expenses for the year ended March 31, 2016 were \$4,480,495 as compared to \$1,331,342 for the year ended March 31, 2015. Consulting fees were comprised of fees paid to the director of our subsidiary, Pacific Green Technologies Limited; professional fees were comprised of legal, audit and accounting costs. The increase in operating expenses is primarily attributed to increases in consulting fees, office and administration expenses, professional fees and travel expenses.

For the year ended March 31, 2016, our company had a net loss of \$7,446,232 (\$0.38 per share) compared to a net loss of \$3,053,395 (\$0.19 per share) for the year ended March 31, 2015. In addition to the operating expenses noted above, for the year ended March 31, 2016, our company had \$1,240,302 (2015 - \$1,372,349) in interest expense, \$1,770,154 in loss on change in fair value of derivative liabilities (2015 - \$349,704), and a loss of \$126,782 (2015 - \$Nil) from impairment of goodwill, offset by a gain on settlement of debt of \$171,501 (2015 - \$Nil).

## Liquidity and Capital Resources

### Working Capital

	At March 31, 2016	At March 31, 2015
Current Assets	\$ 95,851	\$ 43,897
Current Liabilities	\$ 11,266,656	\$ 9,996,313
Working Capital (Deficit)	<u>\$ (11,170,805)</u>	<u>\$ (9,952,416)</u>

### Cash Flows

	Year Ended March 31, 2016	Year Ended March 31, 2015
Net Cash Used in Operating Activities	\$ (1,101,335)	\$ (53,612)
Net Cash Provided by (Used in) Investing Activities	\$ 50,064	\$ (46,681)
Net Cash Provided by Financing Activities	\$ 1,035,004	\$ 382,865
Effect of Exchange Rate Changes on Cash	\$ 55,105	\$ (486,873)
Net Increase (Decrease) in Cash	<u>\$ 38,838</u>	<u>\$ (204,301)</u>

As of March 31, 2016, we had \$40,108 in cash, \$95,851 in total current assets, \$11,266,656 in total current liabilities and a working capital deficit of \$11,170,805 compared to a working capital deficit of \$9,952,416 at March 31, 2015.

We spent \$1,101,335 on operating activities during the year ended March 31, 2016 and \$53,612 on operating activities during the year ended March 31, 2015. The increase in our expenditures on operating activities during the year ended March 31, 2016 was primarily due to increases in operating expenses and operating assets and liabilities.

During the year ended March 31, 2016, we received \$1,035,004 from financing activities, which consisted of \$100,000 in proceeds from convertible debentures, \$1,275,000 proceeds from the issuance of our common shares and \$19,804 in advances from related parties offset by a \$359,800 repayment to related parties. During the year ended March 31, 2015, we received \$382,865 which consisted of \$300,000 in proceeds from convertible debentures and \$137,822 in advances from related parties offset by a \$54,957 repayment to related parties.



During the year ended March 31, 2016, we received \$50,064 from investing activities, which consisted of \$50,064 from cash acquired on acquisition of our subsidiary. During the year ended March 31, 2015, we used \$46,681 in investing activities, which consisted of \$25,000 in advance of loan receivable and \$21,681 for an advance to a related party.

We will require additional funds to fund our budgeted expenses over the next 12 months. These funds may be raised through, equity financing, debt financing, or other sources, which may result in further dilution in the equity ownership of our shares.

We anticipate that our cash expenses over the next 12 months (beginning August 2016) will be approximately \$1,070,000 as described in the table below. These estimates may change significantly depending on the nature of our business activities and our ability to raise capital from our shareholders or other sources.

Description	Estimated Expenses (\$)
Legal and accounting fees	200,000
Marketing and advertising	25,000
Investor relations and capital raising	50,000
Management and operating costs	100,000
Salaries and consulting fees	320,000
General and administrative expenses	375,000
<b>Total</b>	<b>\$ 1,070,000</b>

Our general and administrative expenses for the year will consist primarily of transfer agent fees, bank and interest charges and general office expenses. The professional fees are related to our regulatory filings throughout the year and include legal, accounting, and auditing fees.

Based on our planned expenditures, we will require approximately \$1,070,000 to proceed with our business plan over the next 12 months. As of March 31, 2016, we had \$40,108 cash on hand. If we secure less than the full amount of financing that we require, we will not be able to carry out our complete business plan and we will be forced to proceed with a scaled back business plan based on our available financial resources.

We intend to raise the balance of our cash requirements for the next 12 months from private placements, shareholder loans, or possibly a registered public offering (either self-underwritten or through a broker-dealer). If we are unsuccessful in raising enough money through such efforts, we may review other financing possibilities such as bank loans. At this time we do not have a commitment from any broker-dealer to provide us with financing. There is no assurance that any financing will be available to us or if available, on terms that will be acceptable to us.

Even though we plan to raise capital through equity or debt financing, we believe that the latter may not be a viable alternative for funding our operations as we do not have sufficient tangible assets to secure any such financing. We anticipate that any additional funding will be in the form of equity financing from the sale of our common stock. However, we do not have any financing arranged and we cannot provide any assurance that we will be able to raise sufficient funds from the sale of our common stock to finance our operations. In the absence of such financing, we may be forced to abandon our business plan.

### Going Concern

Our consolidated financial statements for the year ended March 31, 2016 have been prepared on a going concern basis and contain an additional explanatory paragraph which identifies issues that raise substantial doubt about our ability to continue as a going concern. Our consolidated financial statements do not include any adjustments that might result from the outcome of this uncertainty.

We have generated no revenues, have achieved losses since our inception, and rely upon the sale of our common stock and proceeds from shareholder loans to fund our operations. If we are unable to raise equity or secure alternative financing, we may not be able to continue our operations and our business plan may fail.

If our operations and cash flow improve, management believes that we can continue to operate. However, no assurance can be given that management's actions will result in profitable operations or an improvement in our liquidity situation. The threat of our ability to continue as a going concern will cease to exist only when our revenues have reached a level able to sustain our business operations.

### Off-Balance Sheet Arrangements

We have no significant off-balance sheet arrangements that have or are reasonably likely to have a current or future effect on our financial condition, revenues or expenses, results of operations, liquidity, capital expenditures or capital resources that are material to stockholders.

## **Contractual Obligations**

As a “smaller reporting company”, we are not required to provide tabular disclosure obligations.

## **Critical Accounting Policies**

### *Use of Estimates*

The preparation of these consolidated financial statements in conformity with U.S. generally accepted accounting principles requires management to make estimates and assumptions that affect the reported amounts of assets and liabilities and disclosure of contingent assets and liabilities at the date of the financial statements and the reported amounts of revenue and expenses during the reporting period. Our company regularly evaluates estimates and assumptions related to the useful life and recoverability of intangible assets, valuation of note payable, fair value of convertible debentures, fair value of derivative liabilities, fair value of stock-based compensation, impairment of goodwill, and deferred income tax asset valuation allowances. Our company bases its estimates and assumptions on current facts, historical experience and various other factors that it believes to be reasonable under the circumstances, the results of which form the basis for making judgments about the carrying values of assets and liabilities and the accrual of costs and expenses that are not readily apparent from other sources. The actual results experienced by our company may differ materially and adversely from our company’s estimates. To the extent there are material differences between the estimates and the actual results, future results of operations will be affected.

### *Intangible Assets*

Intangible assets are stated at cost less accumulated amortization and are comprised of patents. The patents are amortized straight-line over the estimated useful life of 17 years.

### *Impairment of Long-lived Assets*

Our company reviews long-lived assets such as property and equipment and intangible assets with finite useful lives for impairment whenever events or changes in circumstance indicate that the carrying amount may not be recoverable. If the total of the expected undiscounted future cash flows is less than the carrying amount of the asset, a loss is recognized for the excess of the carrying amount over the fair value of the asset.

### *Stock-based compensation*

Our company records stock-based compensation in accordance with ASC 718, “Compensation – Stock Compensation”, using the fair value method. All transactions in which goods or services are the consideration received for the issuance of equity instruments are accounted for based on the fair value of the consideration received or the fair value of the equity instrument issued, whichever is more reliably measurable.

Our company uses the Black-Scholes option pricing model to calculate the fair value of stock-based awards. This model is affected by our company’s stock price as well as assumptions regarding a number of subjective variables. These subjective variables include, but are not limited to our company’s expected stock price volatility over the term of the awards, and actual and projected employee stock option exercise behaviors. The value of the portion of the award that is ultimately expected to vest is recognized as an expense in the consolidated statement of operations over the requisite service period.

## **Recent Accounting Pronouncements**

Our company has implemented all new accounting pronouncements that are in effect and that may impact its consolidated financial statements and does not believe that there are any other new accounting pronouncements that have been issued that might have a material impact on its financial position or results of operations.

## **Item 7A. Quantitative and Qualitative Disclosures About Market Risk**

As a “smaller reporting company”, we are not required to provide the information required by this Item.

## **Item 8. Financial Statements and Supplementary Data**

**PACIFIC GREEN TECHNOLOGIES INC.**

Consolidated Financial Statements

March 31, 2016

(Expressed in US dollars)

	<u>Index</u>
Report of Independent Registered Public Accounting Firm	F-1
Consolidated Balance Sheets	F-2
Consolidated Statements of Operations and Comprehensive Loss	F-3
Consolidated Statement of Stockholders' Equity	F-4
Consolidated Statements of Cash Flows	F-5
Notes to the Consolidated Financial Statements	F-6

**REPORT OF INDEPENDENT REGISTERED PUBLIC ACCOUNTING FIRM**

To the Board of Directors and Stockholders of  
Pacific Green Technologies Inc.

We have audited the accompanying consolidated balance sheets of Pacific Green Technologies Inc. (the “Company”) as of March 31, 2016 and 2015, and the related consolidated statements of operations and comprehensive loss, stockholders’ equity, and cash flows for the years then ended. These consolidated financial statements are the responsibility of the Company’s management. Our responsibility is to express an opinion on these consolidated financial statements based on our audits.

We conducted our audits in accordance with the standards of the Public Company Accounting Oversight Board (United States). Those standards require that we plan and perform the audit to obtain reasonable assurance about whether the financial statements are free of material misstatement. An audit includes examining, on a test basis, evidence supporting the amounts and disclosures in the financial statements. The Company is not required to have, nor were we engaged to perform, an audit of its internal control over financial reporting. An audit includes consideration of internal control over financial reporting as a basis for designing audit procedures that are appropriate in the circumstances, but not for the purpose of expressing an opinion on the effectiveness of internal control over financial reporting. Accordingly, we express no such opinion. An audit also includes assessing the accounting principles used and significant estimates made by management, as well as evaluating the overall financial statement presentation. We believe that our audits provide a reasonable basis for our opinion.

In our opinion, the consolidated financial statements referred to above present fairly, in all material respects, the financial position of the Company as of March 31, 2016 and 2015 and the results of its operations and its cash flows for the years then ended, in conformity with accounting principles generally accepted in the United States.

The accompanying consolidated financial statements have been prepared assuming the Company will continue as a going concern. As discussed in Note 1 to the consolidated financial statements, the Company has not generated any revenues, has a working capital deficit, and has incurred operating losses since inception. These factors raise substantial doubt about the Company’s ability to continue as a going concern. Management’s plans in regard to these matters are also discussed in Note 1 to the consolidated financial statements. The consolidated financial statements do not include any adjustments that might result from the outcome of this uncertainty.

/s/ SATURNA GROUP CHARTERED PROFESSIONAL ACCOUNTANTS LLP

Saturna Group Chartered Professional Accountants LLP

Vancouver, Canada

August 11, 2016

**PACIFIC GREEN TECHNOLOGIES INC.**

## Consolidated Balance Sheets

(Expressed in U.S. dollars)

	March 31, 2016 \$	March 31, 2015 \$
<b>ASSETS</b>		
Cash	40,108	1,270
VAT receivable	4,996	5,683
Prepaid expenses	–	687
Loan receivable	–	25,000
Due from related parties (Note 9)	50,747	11,257
Total Current Assets	95,851	43,897
Deferred financing costs	6,120	–
Intangible assets (Note 4)	12,366,555	13,235,230
Total Assets	<u>12,468,526</u>	<u>13,279,127</u>
<b>LIABILITIES AND STOCKHOLDERS' EQUITY</b>		
<b>Current Liabilities</b>		
Accounts payable and accrued liabilities	821,515	638,808
Loan payable (Note 5)	625,574	645,975
Convertible debentures, net of unamortized discount of \$105,018 and \$14,457, respectively (Note 6)	4,982	285,543
Current portion of note payable, net of unamortized discount of \$33,000 and \$33,438, respectively (Note 8)	3,967,000	2,966,562
Due to related parties (Note 9)	5,025,249	5,066,006
Derivative liabilities (Note 7)	822,336	393,419
Total Current Liabilities	11,266,656	9,996,313
Note payable, net of unamortized discount of \$180,507 and \$486,710, respectively (Note 8)	819,493	1,513,290
Total Liabilities	<u>12,086,149</u>	<u>11,509,603</u>
Nature of Operations and Continuance of Business (Note 1)		
Commitments (Note 14)		
Subsequent Events (Note 16)		
<b>Stockholders' Equity</b>		
Preferred stock, 10,000,000 shares authorized, \$0.001 par value Nil shares issued and outstanding	–	–
Common stock, 500,000,000 shares authorized, \$0.001 par value 23,104,908 and 16,321,681 shares issued and outstanding, respectively	23,105	16,322
Common stock issuable (Notes 4 and 10)	150,000	8,868,523
Additional paid-in capital	60,219,306	45,523,380
Accumulated other comprehensive income	120,760	45,861
Deficit	(60,130,794)	(52,684,562)
Total Stockholders' Equity	382,377	1,769,524
Total Liabilities and Stockholders' Equity	<u>12,468,526</u>	<u>13,279,127</u>

(The accompanying notes are an integral part of these consolidated financial statements)

**PACIFIC GREEN TECHNOLOGIES INC.**Consolidated Statements of Operations and Comprehensive Loss  
(Expressed in U.S. dollars)

	Year Ended March 31, 2016 \$	Year Ended March 31, 2015 \$
Expenses		
Advertising and promotion	10,000	–
Amortization of intangible assets	868,675	868,675
Consulting fees (Note 9)	3,216,033	711,579
Foreign exchange gain	(49,257)	(521,925)
Office and miscellaneous	87,065	40,506
Professional fees	224,737	176,796
Transfer agent and filing fees	35,407	31,341
Travel	87,835	24,370
Total expenses	<u>4,480,495</u>	<u>1,331,342</u>
Loss before other income (expense)	<u>(4,480,495)</u>	<u>(1,331,342)</u>
Other income (expense)		
Gain on settlement of debt (Note 10)	171,501	–
Impairment of goodwill (Note 3)	(126,782)	–
Interest expense (Notes 6 and 8)	(1,240,302)	(1,372,349)
Loss on change in fair value of derivative liabilities (Note 7)	(1,770,154)	(349,704)
Total other income (expense)	<u>(2,965,737)</u>	<u>(1,722,053)</u>
Net loss for the year	<u>(7,446,232)</u>	<u>(3,053,395)</u>
Other comprehensive income		
Foreign currency translation gain	74,899	155,001
Comprehensive loss for the year	<u>(7,371,333)</u>	<u>(2,898,394)</u>
Net loss per share, basic and diluted	<u>(0.38)</u>	<u>(0.19)</u>
Weighted average number of shares outstanding	<u>19,833,220</u>	<u>16,321,681</u>

(The accompanying notes are an integral part of these consolidated financial statements)

**PACIFIC GREEN TECHNOLOGIES INC.**  
Consolidated Statement of Stockholders' Equity  
(Expressed in U.S. dollars)

	Common stock		Common Stock Issuable \$	Additional Paid-in Capital \$	Other Comprehensive Income (Loss) \$	Deficit \$	Stockholders' Equity \$
	Shares #	Amount \$					
Balance, March 31, 2014	16,321,681	16,322	8,868,523	44,623,380	(109,140)	(49,631,167)	3,767,918
Imputed interest	-	-	-	900,000	-	-	900,000
Foreign exchange translation gain	-	-	-	-	155,001	-	155,001
Net loss for the year	-	-	-	-	-	(3,053,395)	(3,053,395)
Balance, March 31, 2015	16,321,681	16,322	8,868,523	45,523,380	45,861	(52,684,562)	1,769,524
Shares issued pursuant to private placements	1,933,333	1,933	150,000	1,123,067	-	-	1,275,000
Shares issued pursuant to conversion of loans	1,517,735	1,518	-	1,604,901	-	-	1,606,419
Shares issued for consulting services	1,115,029	1,115	-	1,015,913	-	-	1,017,028
Shares issued pursuant to share exchange agreement	2,217,130	2,217	(8,868,523)	8,866,306	-	-	-
Shares issued for management services	-	-	-	251,577	-	-	251,577
Shares issued pursuant to finder's fee agreement	-	-	-	934,162	-	-	934,162
Imputed interest	-	-	-	900,000	-	-	900,000
Foreign exchange translation gain	-	-	-	-	74,899	-	74,899
Net loss for the year	-	-	-	-	-	(7,446,232)	(7,446,232)
Balance, March 31, 2016	<u>23,104,908</u>	<u>23,105</u>	<u>150,000</u>	<u>60,219,306</u>	<u>120,760</u>	<u>(60,130,794)</u>	<u>382,377</u>

(The accompanying notes are an integral part of these consolidated financial statements)

**PACIFIC GREEN TECHNOLOGIES INC.**

## Consolidated Statements of Cash Flows

(Expressed in U.S. dollars)

	Year Ended March 31, 2016 \$	Year Ended March 31, 2015 \$
Operating Activities		
Net loss for the year	(7,446,232)	(3,053,395)
Adjustments to reconcile net loss to net cash used in operating activities:		
Accretion of discount on note payable and convertible debentures	326,080	440,979
Amortization of deferred financing costs	3,880	-
Amortization of intangible assets	868,675	868,675
Gain on extinguishment of debt	(171,501)	-
Impairment of goodwill	126,782	-
Imputed interest	900,000	900,000
Loss on change in fair value of derivative liabilities	1,770,154	349,704
Stock-based compensation	2,202,767	-
Changes in operating assets and liabilities:		
VAT receivable	687	(3,678)
Prepaid expenses and deposits	687	-
Due from related party	(14,490)	-
Accounts payable and accrued liabilities	185,524	192,606
Due to related parties	145,652	251,497
Net Cash Used In Operating Activities	<u>(1,101,335)</u>	<u>(53,612)</u>
Investing Activities		
Advance of loan receivable	-	(25,000)
Advances to related party	-	(21,681)
Cash acquired on acquisition of subsidiary	50,064	-
Net Cash Provided By(Used In) Investing Activities	<u>50,064</u>	<u>(46,681)</u>
Financing Activities		
Proceeds from related parties	19,804	137,822
Repayments to related parties	(359,800)	(54,957)
Proceeds from the issuance of common shares / share subscriptions received	1,275,000	-
Proceeds from convertible debentures	100,000	300,000
Net Cash Provided by Financing Activities	<u>1,035,004</u>	<u>382,865</u>
Effect of Foreign Exchange Rate Changes on Cash	<u>55,105</u>	<u>(486,873)</u>
Change in Cash	38,838	(204,301)
Cash, Beginning of Year	1,270	205,571
Cash, End of Year	<u>40,108</u>	<u>1,270</u>
Non-cash Investing and Financing Activities:		
Convertible debentures settled with common stock	1,606,419	-
Recognition of convertible debt discount due to derivative	<u>110,000</u>	<u>43,715</u>
Supplemental Disclosures:		
Interest paid	-	-
Income taxes paid	-	-

(The accompanying notes are an integral part of these consolidated financial statements)



## PACIFIC GREEN TECHNOLOGIES INC.

Notes to the Consolidated Financial Statements

March 31, 2016

(Expressed in U.S. Dollars)

### 1. Nature of Operations and Continuance of Business

Pacific Green Technologies Inc. (the "Company") was incorporated in Delaware on March 10, 1994, under the name of Beta Acquisition Corp. In September 1995, the Company changed its name to In-Sports International, Inc. In August 2002, the Company changed its name to ECash, Inc. On June 13, 2012, the Company changed its name to Pacific Green Technologies Inc.

On June 14, 2012, the Company acquired Pacific Green Technologies Marine Limited (formerly Pacific Green Technologies Limited) ("PGTML") in exchange for the issuance of 5,000,000 shares of common stock and a \$5,000,000 promissory note. The transaction resulted in the former shareholders of PGTML collectively owing a majority of the issued and outstanding common shares of the Company. The accounting principle applicable to a reverse takeover ("RTO") was applied to account for this transaction. Under this basis of accounting, PGT Limited has been identified as the acquirer and, accordingly, these consolidated financial statements are a continuation of the business of PGTML.

On May 15, 2013, the Company acquired Pacific Green Technologies International Limited (formerly Pacific Green Energy Parks Limited) ("PGTIL") and its wholly-owned subsidiary, Energy Park Sutton Bridge ("EPSB") in exchange for a cash payment of \$100 and the issuance of 3,500,000 shares of common stock. In addition to the acquisition agreement, the Company is committed to issuing a further \$3,000,000 payable in common shares in the event PGTIL either purchased the property or secured a lease permitting PGTIL to operate a biomass power plant facility and a further \$33,000,000 payable in common shares in the event PGTIL secures sufficient financing to construct the facility (Refer to Note 14). The consolidated statement of operations and comprehensive loss includes the operations of PGTIL and EPSB commencing from May 16, 2013.

These consolidated financial statements have been prepared on a going concern basis, which implies the Company will continue to realize its assets and discharge its liabilities in the normal course of business. The continuation of the Company as a going concern is dependent upon the continued financial support from its shareholders and note holders, the ability of the Company to obtain necessary equity financing to continue operations, and ultimately the attainment of profitable operations. As at March 31, 2016, the Company has not generated any revenues, has a working capital deficit of \$11,170,805, and has an accumulated deficit of \$60,130,794 since inception. These factors raise substantial doubt regarding the Company's ability to continue as a going concern. These consolidated financial statements do not include any adjustments to the recoverability and classification of recorded asset amounts and classification of liabilities that might be necessary should the Company be unable to continue as a going concern.

### 2. Significant Accounting Policies

#### (a) Basis of Presentation

These consolidated financial statements and related notes are presented in accordance with accounting principles generally accepted in the United States, and are expressed in U.S. dollars. These consolidated financial statements include the accounts of the Company and the following entities:

Pacific Green Technologies Marine Limited (formerly Pacific Green Technologies Limited) ("PGTML")	Wholly-owned subsidiary
Pacific Green Technologies International Limited (formerly Pacific Green Energy Parks Limited) ("PGTIL")	Wholly-owned subsidiary
Energy Park Sutton Bridge Ltd. ("EPSB")	Wholly-owned subsidiary of PGTIL
Pacific Green Technologies Asia Limited ("PGTA")	Wholly-owned subsidiary of PGTIL
Pacific Green Technologies China Limited ("PGTC")	Wholly-owned subsidiary of PGTA

All inter-company balances and transactions have been eliminated.

#### (b) Use of Estimates

The preparation of these consolidated financial statements in conformity with U.S. generally accepted accounting principles requires management to make estimates and assumptions that affect the reported amounts of assets and liabilities and disclosure of contingent assets and liabilities at the date of the financial statements and the reported amounts of revenue and expenses during the reporting period. The Company regularly evaluates estimates and assumptions related to the useful life and recoverability of intangible assets, valuation of note payable, fair value of convertible debentures, fair value of derivative liabilities, fair value of stock-based compensation, impairment of goodwill, and deferred income tax asset valuation allowances. The Company bases its estimates and assumptions on current facts, historical experience and various other factors that it believes to be reasonable under the circumstances, the results of which form the basis for making judgments about the carrying values of assets and liabilities and the accrual of costs and expenses that are not readily apparent from other sources. The actual results experienced by the Company may differ materially and adversely from the Company's estimates. To the extent there are material differences between the estimates and the actual results, future results of operations will be affected.

**2. Significant Accounting Policies** (continued)

(c) Cash and Cash Equivalents

The Company considers all highly liquid instruments with maturity of three months or less at the time of issuance to be cash equivalents.

(d) Intangible Assets

Intangible assets are stated at cost less accumulated amortization and are comprised of patents. The patents are amortized straight-line over the estimated useful life of 17 years.

(e) Impairment of Long-lived Assets

The Company reviews long-lived assets such as property and equipment and intangible assets with finite useful lives for impairment whenever events or changes in circumstance indicate that the carrying amount may not be recoverable. If the total of the expected undiscounted future cash flows is less than the carrying amount of the asset, a loss is recognized for the excess of the carrying amount over the fair value of the asset.

(f) Financial Instruments and Fair Value Measurements

ASC 820, "Fair Value Measurements and Disclosures" requires an entity to maximize the use of observable inputs and minimize the use of unobservable inputs when measuring fair value. ASC 820 establishes a fair value hierarchy based on the level of independent, objective evidence surrounding the inputs used to measure fair value. A financial instrument's categorization within the fair value hierarchy is based upon the lowest level of input that is significant to the fair value measurement. ASC 820 prioritizes the inputs into three levels that may be used to measure fair value:

*Level 1*

Level 1 applies to assets or liabilities for which there are quoted prices in active markets for identical assets or liabilities.

*Level 2*

Level 2 applies to assets or liabilities for which there are inputs other than quoted prices that are observable for the asset or liability such as quoted prices for similar assets or liabilities in active markets; quoted prices for identical assets or liabilities in markets with insufficient volume or infrequent transactions (less active markets); or model-derived valuations in which significant inputs are observable or can be derived principally from, or corroborated by, observable market data.

*Level 3*

Level 3 applies to assets or liabilities for which there are unobservable inputs to the valuation methodology that are significant to the measurement of the fair value of the assets or liabilities.

The Company's financial instruments consist principally of cash, VAT receivable, loan receivable, amounts due from and to related parties, accounts payable and accrued liabilities, loan payable, convertible debentures, and note payable. With the exception of long-term note payable, the recorded values of all other financial instruments approximate their current fair values because of their nature and respective maturity dates or durations.

The following table represents assets and liabilities that are measured and recognized at fair value as of March 31, 2016, on a recurring basis:

	Level 1	Level 2	Level 3	Total gains (losses)
	\$	\$	\$	\$
Cash	40,108	–	–	–
Derivative liabilities	–	822,336	–	(1,770,154)
<b>Total</b>	<b>40,108</b>	<b>822,336</b>	<b>–</b>	<b>(1,770,154)</b>

During the year ended March 31, 2016, the Company recognized a loss on change in fair value of derivative liabilities of \$1,770,154 (2015 - \$349,704).

**PACIFIC GREEN TECHNOLOGIES INC.**

Notes to the Consolidated Financial Statements

March 31, 2016

(Expressed in U.S. Dollars)

**2. Significant Accounting Policies** (continued)

(g) Income Taxes

The Company accounts for income taxes using the asset and liability method in accordance with ASC 740, Income Taxes. The asset and liability method provides that deferred tax assets and liabilities are recognized for the expected future tax consequences of temporary differences between the financial reporting and tax bases of assets and liabilities, and for operating loss and tax credit carry-forwards. Deferred tax assets and liabilities are measured using the currently enacted tax rates and laws that will be in effect when the differences are expected to reverse. The Company records a valuation allowance to reduce deferred tax assets to the amount that is believed more likely than not to be realized.

The Company has not recorded any amounts pertaining to uncertain tax positions.

(h) Foreign Currency Translation

The Company's functional and reporting currency is the United States dollar. The functional currencies of PGTML, PGTIL, and EPSB are in Great British pounds. The functional currencies of PGTA and PGTC are the United States dollar. Monetary assets and liabilities denominated in foreign currencies are translated using the exchange rate prevailing at the balance sheet date. Non-monetary assets, liabilities and items recorded in income arising from transactions denominated in foreign currencies are translated at rates of exchange in effect at the date of the transaction. Gains and losses arising on translation or settlement of foreign currency denominated transactions or balances are included in the determination of income.

The accounts of PGTML, PGTIL, and ESPB are translated to United States dollars using the current rate method. Accordingly, assets and liabilities are translated into United States dollars at the period-end exchange rate while revenue and expenses are translated at the average exchange rates during the period. Related exchange gains and losses are included in a separate component of stockholders' equity as accumulated other comprehensive income (loss).

(i) Stock-based compensation

The Company records stock-based compensation in accordance with ASC 718, "Compensation – Stock Compensation", using the fair value method. All transactions in which goods or services are the consideration received for the issuance of equity instruments are accounted for based on the fair value of the consideration received or the fair value of the equity instrument issued, whichever is more reliably measurable.

The Company uses the Black-Scholes option pricing model to calculate the fair value of stock-based awards. This model is affected by the Company's stock price as well as assumptions regarding a number of subjective variables. These subjective variables include, but are not limited to the Company's expected stock price volatility over the term of the awards, and actual and projected employee stock option exercise behaviors. The value of the portion of the award that is ultimately expected to vest is recognized as an expense in the consolidated statement of operations over the requisite service period.

(j) Loss Per Share

The Company computes net income (loss) per share in accordance with ASC 260, Earnings per Share. ASC 260 requires presentation of both basic and diluted earnings per share (EPS) on the face of the income statement. Basic EPS is computed by dividing net income (loss) available to common shareholders (numerator) by the weighted average number of shares outstanding (denominator) during the period. Diluted EPS gives effect to all dilutive potential common shares outstanding during the period using the treasury stock method and convertible preferred stock using the if-converted method. In computing diluted EPS, the average stock price for the period is used in determining the number of shares assumed to be purchased from the exercise of stock options or warrants. Diluted EPS excludes all dilutive potential shares if their effect is anti-dilutive. As at March 31, 2016, the Company had 4,195,201 (2015 - 640,155) potentially dilutive shares outstanding.

(k) Comprehensive Loss

Comprehensive loss consists of net loss and other related gains and losses affecting stockholders' equity that are excluded from net income or loss. As at March 31, 2016 and 2015, comprehensive loss includes cumulative translation adjustments for changes in foreign currency exchange rates during the period.

(l) Recent Accounting Pronouncements

The Company has implemented all new accounting pronouncements that are in effect and that may impact its consolidated financial statements and does not believe that there are any other new accounting pronouncements that have been issued that might have a material impact on its financial position or results of operations.



**3. Acquisition of Pacific Green Technologies Asia Limited and Pacific Green Technologies China Limited**

On June 30, 2015, PGTIL entered into a share purchase agreement whereby the Company acquired 100 common shares of PGTA, representing 100% of the issued and outstanding shares, for consideration of \$1. This formalized the Company's structure of corporate entities for conducting business in Asian markets. PGTA is the sole shareholder of PGTC.

In accordance with ASC 805, "Business Combinations", the purchase agreement was deemed a business combination for accounting purposes. At the date of acquisition, the fair values of the assets and liabilities of PGTA and its wholly owned subsidiary PGTC consisted of the following:

	\$
Cash	50,064
Goodwill	126,782
Accounts payable and accrued liabilities	(23,865)
Due to related parties	(152,980)
Total purchase price	<u>1</u>

As PGTA and PGTC were dependent on the Company for funding prior to acquisition and were at non-arms' length with the Company, the Company recorded an impairment of goodwill of \$126,782 as a cost of acquisition.

**4. Intangible Assets**

	Cost \$	Accumulated amortization \$	Impairment \$	March 31, 2016 Net carrying value \$	March 31, 2015 Net carrying value \$
Patents and technical information	<u>35,852,556</u>	<u>(3,028,746)</u>	<u>(20,457,255)</u>	<u>12,366,555</u>	<u>13,235,230</u>

On May 17, 2013, the Company entered into an Assignment of Assets agreement with EnviroTechnologies, Inc. ("Enviro"), whereby the Company acquired various patents and technical information related to the manufacture of a wet scrubber for removing sulphur, other pollutants, and the particulate matter from diesel engine exhaust. In exchange for these assets, the Company waived all obligations owing to the Company as well as agreed to return a total of 88,876,443 of Enviro's shares back to Enviro. The obligations waived consisted of \$237,156 owing to the Company as well as \$93,721 of debt owing to Pacific Green Group Limited ("PGG"), which was assigned to the Company. The Company entered into share exchange agreements with Enviro shareholders pursuant to which it issued shares of its common stock in exchange for shares of Enviro on a one-for-ten basis. As at March 31, 2016, the Company has nil (2015 - 2,217,130) shares of its common stock issuable to Enviro shareholders at a fair value of \$nil (2015 - \$8,868,523), which was recorded as common stock issuable. Refer to Notes 10(g) and 10(k). The intangible assets acquired were recorded at cost and is being amortized using the straight-line method over the estimated useful life of 17 years.

**5. Loan Payable**

As at March 31, 2016, PGTIL, the Company's wholly owned subsidiary, owes \$625,574 (£435,000) (2015 - \$645,975 (£435,000)) to a director of the Company, which is non-interest bearing, unsecured, and due on demand.

**6. Convertible Debentures**

(a) On May 27, 2014, the Company entered into a \$200,000 convertible debenture with a non-related party. Under the terms of the debenture, the amount is unsecured, bears interest at 10% per annum, and is due on May 27, 2015. Pursuant to the agreement, should any portion of the loan remain outstanding past maturity, the interest rate will increase to 15% per annum. The note is convertible into shares of common stock 180 days after the date of issuance (November 27, 2014) until maturity at a conversion rate of 75% of the average closing bid prices of the Company's common stock for the 45 days ending one trading day prior to the date the conversion notice is sent by the holder to the Company. As at March 31, 2016, the Company recorded accrued interest of \$nil (2015 - \$17,458), which has been included in accounts payable and accrued liabilities.

**PACIFIC GREEN TECHNOLOGIES INC.**

Notes to the Consolidated Financial Statements

March 31, 2016

(Expressed in U.S. Dollars)

**6. Convertible Debentures (continued)**

The Company analyzed the conversion option under ASC 815, "Accounting for Derivative Instruments and Hedging Activities" ("ASC 815"), and determined that the conversion feature should be classified as a liability and recorded at fair value due to there being no explicit limit to the number of shares to be delivered upon settlement of the conversion option. In accordance with ASC 815, the Company recognized the intrinsic value of the embedded beneficial conversion feature of \$33,922. On November 27, 2014, the note became convertible resulting in the Company recording a derivative liability of \$33,922 with a corresponding adjustment to loss on change in fair value of derivative liabilities. During year ended March 31, 2016, the Company had amortized \$12,820 (2015 - \$21,102) of the debt discount to interest expense. On May 4, 2015, the Company issued 1,058,317 shares of common stock for the conversion of \$200,000 of this debenture and \$18,888 of accrued interest. Refer to Note 10(a). As at March 31, 2016, the carrying value of the debenture was \$nil (2015 - \$187,180) and the fair value of the derivative liability was \$nil (2015 - \$268,716).

- (b) On June 12, 2014, the Company entered into a \$100,000 convertible debenture with a non-related party. Under the terms of the debenture, the amount is unsecured, bears interest at 10% per annum, and is due on June 12, 2015. Pursuant to the agreement, should any portion of the loan remain outstanding past maturity, the interest rate will increase to 15% per annum. The note is convertible into shares of common stock 180 days after the date of issuance (December 12, 2014) until maturity at a conversion rate of 75% of the average closing bid prices of the Company's common stock for the 45 days ending one trading day prior to the date the conversion notice is sent by the holder to the Company. As at March 31, 2016, the Company recorded accrued interest of \$nil (2015 - \$7,092), which has been included in accounts payable and accrued liabilities.

The Company analyzed the conversion option under ASC 815, and determined that the conversion feature should be classified as a liability and recorded at fair value due to there being no explicit limit to the number of shares to be delivered upon settlement of the conversion option. In accordance with ASC 815, the Company recognized the intrinsic value of the embedded beneficial conversion feature of \$9,793. On December 12, 2014, the note became convertible resulting in the Company recording a derivative liability of \$9,793 with a corresponding adjustment to loss on change in fair value of derivative liabilities. During the year ended March 31, 2016, the Company had amortized \$1,637 (2015 - \$8,156) of the debt discount to interest expense. On May 13, 2015, the Company issued 459,418 shares of common stock for the conversion of \$100,000 of this debenture and \$7,796 of accrued interest. Refer to Note 10(b). As at March 31, 2016, the carrying value of the debenture was \$nil (2015 - \$98,363) and the fair value of the derivative liability was \$nil (2015 - \$124,703).

- (c) On November 10, 2015, the Company entered into a \$110,000 convertible debenture with a non-related party, in exchange for \$100,000, net of \$10,000 for legal fees which have been deferred and will be amortized over the term of the debenture. Under the terms of the debenture, the amount is unsecured, bears interest at 10% per annum, and is due on November 10, 2016. The note is convertible into shares of common stock of the Company equal to the lower of: (a) \$0.40 or (b) 60% of the lowest trading price of the Company's common stock during the 20 consecutive trading days prior to the date of conversion. During the year ended March 31, 2016, the Company amortized \$3,880 (2015 - \$nil) of the deferred financing costs. As at March 31, 2016, the Company recorded accrued interest of \$11,000 (2015 - \$nil), which has been included in accounts payable and accrued liabilities.

The Company analyzed the conversion option under ASC 815, and determined that the conversion feature should be classified as a liability and recorded at fair value due to there being no explicit limit to the number of shares to be delivered upon settlement of the conversion option. In accordance with ASC 815, the Company recognized the intrinsic value of the embedded beneficial conversion feature of \$110,000. During the year ended March 31, 2016, the Company had amortized \$4,982 (2015 - \$nil) of the debt discount to interest expense. As at March 31, 2016, the carrying value of the debenture was \$4,982 (2015 - \$nil) and the fair value of the derivative liability was \$822,336 (2015 - \$nil).

**7. Derivative Liabilities**

The Company records the fair value of the of the conversion price of the convertible debentures disclosed in Note 6 in accordance with ASC 815. The fair value of the derivative was calculated using a binomial option pricing model. The fair value of the derivative liability is revalued on each balance sheet date with corresponding gains and losses recorded in the consolidated statement of operations. During the year ended March 31, 2016, the Company recorded a loss on the change in fair value of derivative liability of \$1,770,154 (2015 - \$349,704). As at March 31, 2016, the Company recorded a derivative liability of \$822,336 (2015 - \$393,419).

**PACIFIC GREEN TECHNOLOGIES INC.**  
Notes to the Consolidated Financial Statements  
March 31, 2016  
(Expressed in U.S. Dollars)

**7. Derivative Liabilities** (continued)

The following inputs and assumptions were used to calculate the fair value the convertible debentures outstanding during the year ended March 31, 2016:

	May 27, 2014		June 12, 2014		November 10, 2015	
	Convertible Debenture		Convertible Debenture		Convertible Debenture	
	As at May 4, 2015	As at March 31, 2015	As at May 13, 2015	As at March 31, 2015	As at March 31, 2016	As at November 10, 2015
Estimated common stock issuable upon extinguishment	1,219,432	438,135	466,649	202,020	302,500	359,477
Estimated exercise price	0.18	0.50	0.23	0.50	0.40	0.31
Risk-free interest rate	1%	3%	2%	3%	0.1%	0.1%
Expected dividend yield	—	—	—	—	—	—
Expected volatility	147%	195%	141%	189%	250%	194%
Expected life (in years)	0.06	0.16	0.08	0.20	0.61	1.00

A summary of the activity of the derivative liability is shown below:

	\$
Balance, March 31, 2014	—
Debt discount due to derivative	43,715
Mark to market adjustment	349,704
Balance, March 31, 2015	393,419
Debt discount due to derivative	110,000
Mark to market adjustment	1,770,154
Adjustment for extinguishments	(1,451,237)
Balance, March 31, 2016	822,336

**8. Note Payable**

	March 31, 2016	March 31, 2015
	\$	\$
Opening balance	4,479,852	4,068,131
Accretion of unamortized discount	306,641	411,721
Ending balance	4,786,493	4,479,852
Less: current portion	(3,967,000)	(2,966,562)
Long-term portion	819,493	1,513,290

The principal repayments of the note payable are as follows:

	\$
June 12, 2013	1,000,000
June 12, 2014	1,000,000
June 12, 2015	1,000,000
June 12, 2016	1,000,000
June 12, 2017	1,000,000
	5,000,000

On June 14, 2012, the Company entered into an Assignment and Share Transfer Agreement with PGG, a company under common control, concerning the assignment of the Representation Agreement entered between PGG and Enviro and the purchase of 100% of the issued and outstanding common shares of PGT Limited, a subsidiary of PGG, in exchange for an aggregate of 5,000,000 shares of common stock as well as a \$5,000,000 promissory note.

## PACIFIC GREEN TECHNOLOGIES INC.

Notes to the Consolidated Financial Statements

March 31, 2016

(Expressed in U.S. Dollars)

### 8. Note Payable (continued)

The note payable will be repaid in instalments of \$1,000,000 on the anniversary of the agreement beginning on June 12, 2013 with the income earned under the terms of the Representation Agreement. If the Company is unable to meet the repayment schedule, PGG will have the option to either roll over any unpaid portion to the following payment date or to convert the outstanding amount into shares of the Company's stock. The note had been discounted at a market rate of 18% to arrive at the net present value of \$3,127,171 as at June 12, 2012. The note is unsecured and cannot itself be used by PGG to cause the Company to become insolvent. During the year ended March 31, 2016, the Company recorded imputed interest of \$900,000 (2015 - \$900,000) at a rate of 18% per annum which has been included in additional paid-in capital.

### 9. Related Party Transactions

- (a) As at March 31, 2016, the Company was owed \$38,506 (2015 - \$nil) from a company controlled by a significant shareholder of the Company.
- (b) As at March 31, 2016, the Company was owed \$11,257 (2015 - \$11,257) from a director of the Company. The amount owing is unsecured, non-interest bearing, and due on demand.
- (c) As at March 31, 2016, the Company was owed \$984 (2015 - \$nil) from a significant shareholder of the Company.
- (d) As at March 31, 2016, the Company owed \$4,862,555 (2015 - \$4,937,037) to a company controlled by a significant shareholder of the Company. Of this amount, \$nil (2015 - \$49,096) is unsecured, bears interest at the US Bank Prime Rate plus 4%, and due on demand. The remainder of the amount owing is unsecured, non-interest bearing, and due on demand. On July 20, 2015, the Company entered into a conversion agreement with the significant shareholder, whereby up to \$1,000,000 in outstanding amounts may be converted at a rate of \$0.70 per share for a 12 month period between July 20, 2016 and July 20, 2017. The Company determined that the convertible debt contained no embedded beneficial conversion feature as the conversion price was the same as the fair market value of the Company's common stock on the date of issuance.
- (e) As at March 31, 2016, the Company owed \$38,430 (2015 - \$98,389) to a significant shareholder of the Company. Of this amount, \$20,765 (2015 - \$79,219) is unsecured, bears interest at the US Bank Prime Rate plus 4%, and due on demand. The remainder of the amount owing is unsecured, non-interest bearing, and due on demand.
- (f) As at March 31, 2016, the Company owed \$124,264 (2015 - \$818) to directors of the Company's wholly-owned subsidiaries. The amounts owing are unsecured, non-interest bearing, and due on demand.
- (g) As at March 31, 2016, the Company owed \$nil (2015 - \$29,762 (£20,042)) to a company under common control. The amount owing is unsecured, non-interest bearing, and due on demand.
- (h) During the year ended March 31, 2016, the Company incurred \$1,174,164 (2015 - \$240,000) in consulting fees to a company controlled by a significant shareholder of the Company. Of this amount, \$934,163 relates to the fair value of 934,963 share purchase warrants in consideration for finder's fees incurred. The share purchase warrants are exercisable at a price of \$0.001 per share for a term of two years. Refer to Note 11.
- (i) During the year ended March 31, 2016, the Company incurred \$17,696 (2015 - \$26,280) in consulting fees to a company controlled by a director of the Company.
- (j) During the year ended March 31, 2016, the Company incurred \$173,862 (2015 - \$nil) in consulting fees to a director of the Company.
- (k) During the year ended March 31, 2016, the Company incurred \$251,577 (2015 - \$nil) in consulting fees for stock options vested to an officer and a director of the Company.

### 10. Common Stock

- (a) On May 4, 2015, the Company issued 1,058,317 shares of common stock with a fair value of \$1,068,900 pursuant to a settlement agreement for the extinguishment of \$200,000 in principal, \$18,888 in accrued interest, and the \$1,012,876 derivative liability relating to the May 27, 2014 convertible debenture. The fair value of the common stock was determined based on the closing price of the Company's common stock. This transaction resulted in a gain on extinguishment of debt of \$162,864. Refer to Note 6(a).



**PACIFIC GREEN TECHNOLOGIES INC.**

Notes to the Consolidated Financial Statements

March 31, 2016

(Expressed in U.S. Dollars)

**10. Common Stock** (continued)

- (b) On May 13, 2015, the Company issued 459,418 shares of common stock with a fair value of \$537,519 pursuant to a settlement agreement for the extinguishment of \$100,000 in principal, \$7,795 in accrued interest, and the \$438,361 derivative liability relating to the June 12, 2014 convertible debenture. The fair value of the common stock was determined based on the closing price of the Company's common stock. This transaction resulted in a gain on extinguishment of debt of \$8,637. Refer to Note 6(b).
- (c) On August 10, 2015, the Company issued 50,000 shares of common stock to a company controlled by a director of the Company relating to a non-brokered private placement on May 20, 2015 at a price of \$0.50 per share for proceeds of \$25,000. In consideration for the share subscription, the Company granted the subscriber an option to purchase a minimum of \$93,750 to a maximum of \$125,000 of shares of common stock. The option vests upon the Company entering into a binding agreement for the sale or license of its ENVI-Clean or ENVI-Pure emission control technology system (the "Option Event") and must be exercised within 28 days of the Option Event. The option expires on May 20, 2017 and is exercisable at a conversion rate of 75% of the average closing bid prices of the Company's common stock for the 10 trading days prior to the Option Event and the 10 trading days after the Option Event. The exercise price shall not be less than \$1.00 per share and not greater than \$2.50 per share. The option vested on November 17, 2015 when the Company entered into a commercial joint venture agreement. Refer to Notes 12 and 14(d).
- (d) On August 10, 2015, the Company issued 550,000 shares of common stock relating to a non-brokered private placement on May 26, 2015 at a price of \$0.50 per share for proceeds of \$275,000. In consideration for the share subscription, the Company granted the subscriber an option to purchase a minimum of \$1,031,250 to a maximum of \$1,375,000 of shares of common stock. The option vests upon the Company entering into a binding agreement for the sale or license of its ENVI-Clean or ENVI-Pure emission control technology system and must be exercised within 28 days of the Option Event. The option expires on May 22, 2017 and is exercisable at a conversion rate of 75% of the average closing bid prices of the Company's common stock for the 10 trading days prior to the Option Event and the 10 trading days post the Option Event. The exercise price shall not be less than \$1.00 per share and not greater than \$2.50 per share. The option vested on November 17, 2015 when the Company entered into a commercial joint venture agreement. Refer to Notes 12 and 14(d).
- (e) On August 10, 2015, the Company issued 100,000 shares of common stock relating to a non-brokered private placement on June 6, 2015 at a price of \$0.50 per share for proceeds of \$50,000. In consideration for the share subscription, the Company granted the subscriber an option to purchase an additional \$250,000 of shares of common stock at \$1.50 per share, expiring on June 6, 2017. The option vests upon the Company entering into a binding agreement for the sale or license of its ENVI-Clean or ENVI-Pure emission control technology system and must be exercised within 21 days of the Option Event. The option vested on November 17, 2015 when the Company entered into a commercial joint venture agreement. Refer to Notes 12 and 14(d).
- (f) On August 10, 2015, the Company issued 600,000 shares of common stock relating to a non-brokered private placement on June 10, 2015 at a price of \$0.50 per share for proceeds of \$300,000. In consideration for the share subscription, the Company granted the subscriber an option to purchase an additional \$1,500,000 of shares of common stock at \$1.50 per share, expiring on June 6, 2017. The option vests upon the Company entering into a binding agreement for the sale or license of its ENVI-Clean or ENVI-Pure emission control technology system and must be exercised within 21 days of the Option Event. The option vested on November 17, 2015 when the Company entered into a commercial joint venture agreement. Refer to Notes 12 and 14(d).
- (g) On October 2, 2015, the Company issued 960,017 shares of common stock with a fair value of \$3,840,068 (included in common stock issuable as at March 31, 2015) in a share exchange agreement with the shareholders of Enviro for the acquisition of 9,600,167 shares of common stock which were subsequently returned to Enviro pursuant to the Assignment of Assets agreement dated May 15, 2013. Refer to Note 4.
- (h) On October 20, 2015, the Company issued 200,000 shares of common stock with a fair value of \$102,000 pursuant to the consulting agreement described in Note 14(c). The fair value of the common stock was determined based on the closing price of the Company's common stock.

**PACIFIC GREEN TECHNOLOGIES INC.**  
Notes to the Consolidated Financial Statements  
March 31, 2016  
(Expressed in U.S. Dollars)

**10. Common Stock** (continued)

- (i) On December 11, 2015, the Company issued 433,333 shares of common stock relating to a non-brokered private placement at a price of \$0.75 per share for proceeds of \$325,000.
- (j) On December 15, 2015, the Company issued 200,000 shares of common stock relating to a non-brokered private placement at a price of \$0.75 per share for proceeds of \$150,000.
- (k) On February 10, 2016, the Company issued 1,257,113 shares of common stock with a fair value of \$5,028,455 (included in common stock issuable as at March 31, 2015) in a share exchange agreement with the shareholders of Enviro for the acquisition of 12,571,165 shares of common stock which were subsequently returned to Enviro pursuant to the Assignment of Assets agreement dated May 14, 2013. Refer to Note 4.
- (l) On February 10, 2016, the Company issued 915,029 shares of common stock with a fair value of \$915,028 to a various consultants for consulting services. The fair value of the common stock was determined based on the closing price of the Company's common stock.
- (m) As at March 31, 2016, the Company had \$150,000 of share subscription proceeds for 150,000 shares of common stock at \$1.00 per share recorded in common stock issuable to a company controlled by a director of the Company. Refer to Note 16(d).

**11. Share Purchase Warrants**

	Number of warrants	Weighted average exercise price \$
Balance, March 31, 2014 and 2015	–	–
Issued	934,963	0.001
Balance, March 31, 2016	<u>934,963</u>	<u>0.001</u>

As at March 31, 2016, the following share purchase warrants were outstanding:

Number of warrants outstanding	Exercise price \$	Expiry date
<u>934,963</u>	<u>0.001</u>	<u>January 8, 2018</u>

The fair value for share purchase warrants issued have been estimated using the Black-Scholes option pricing model assuming no expected dividends and the following weighted average assumptions:

	2016	2015
Risk-free interest rate	1.5%	–
Expected life (in years)	2.0	–
Expected volatility	207%	–

On January 8, 2016, the Company issued 934,963 share purchase warrants with a fair value of \$934,163 to a company controlled by a director of the Company for consulting services. Each warrant is convertible into one common share of the Company at an exercise price of \$0.001 per share expiring on January 8, 2018.

**PACIFIC GREEN TECHNOLOGIES INC.**  
Notes to the Consolidated Financial Statements  
March 31, 2016  
(Expressed in U.S. Dollars)

**12. Stock Options**

The following table summarizes the continuity of stock options:

	Number of options	Weighted average exercise price \$	Weighted average remaining contractual life (years)	Aggregate intrinsic value \$
Balance, March 31, 2014	62,500	0.01	0.7	430,625
Expired	(62,500)	0.01		
Balance, March 31, 2015	–	–	–	–
Granted	3,029,167	1.07		
Expired	(1,500,000)	1.00		
Balance, March 31, 2016	<u>1,529,167</u>	<u>1.15</u>	<u>0.7</u>	<u>2,833,876</u>

Additional information regarding stock options outstanding as at March 31, 2016 is as follows:

Range of exercise prices \$	Outstanding and exercisable		
	Number of shares	Weighted average remaining contractual life (years)	Weighted average exercise price \$
0.01	362,500	2.3	0.01
1.50	1,166,667	0.2*	1.50
	<u>1,529,167</u>	<u>0.7</u>	<u>1.15</u>

\* These stock options expire within 28 days of the Company entering into a binding agreement for the sale or license of its ENVI-Clean or ENVI-Pure emission control technology system. On May 4 and May 5, 2016, the Company extended the expiry date of the stock options to June 30, 2016. Refer to Notes 16(b) and 16(c).

The fair value for 362,500 stock options granted to the directors and officers have been estimated using the Black-Scholes option pricing model assuming no expected dividends or forfeitures and the following weighted average assumptions:

	2016	2015
Risk-free interest rate	1.06%	–
Expected life (in years)	3.0	–
Expected volatility	171%	–

The fair value for 2,666,667 stock options granted to the investors vest upon the Company entering into a binding agreement for the sale or license of its ENVI-Clean or ENVI-Pure emission control technology system (the "Option Event"). The options vested on November 17, 2015 when the Company entered into a commercial joint venture agreement and have been estimated using the binomial option pricing model assuming no expected dividends and the following inputs and assumptions:

	2016	2015
Estimated exercise price	1.22	–
Risk-free interest rate	0.07%	–
Expected life (in years)	0.1	–
Expected volatility	263%	–

The fair value of stock options vested during the year ended March 31, 2016 was \$251,577 (2015 - \$nil), which was recorded as additional paid-in capital and charged to operations. The weighted average fair value of stock options granted during the year ended March 31, 2016 was \$0.08 (2015 – \$nil) per option.

**13. Segmented Information**

The Company is located and operates in the US and its subsidiaries are primarily located and operating in the United Kingdom and China. All non-current assets are located in the US.

**14. Commitments**

- (a) On May 1, 2010, the Company entered into consulting agreements with Sichel Limited (“Sichel”), the parent company of PGG. Sichel will assist the Company in developing commercial agreements for green technology and the building of an international distribution centre. Effective December 31, 2013, this consulting agreement was assigned to Pacific Green Development Ltd. The agreement shall continue for four years with consideration as follows:
- i) Stock consideration to PGG or to any third party as directed by PGG of 5,000 ordinary shares of common stock of the Company upon signing of the agreement, which have been waived by PGG;
  - ii) Monthly consultancy fees of \$20,000 are to be paid within fourteen days of each month-end. If the Company is unable to pay this fee, then PGG has the option to elect to be paid 5,000 shares of common stock of the Company in lieu of cash;
  - iii) Sales commission of 10% of sales value excluding shipping and local sales taxes; and
  - iv) Finance commission of 10% of net proceeds of any funds raised by way of issued of stock, debt or convertible note after any brokers commission as introduced by PGG.
- (b) On May 15, 2013, the Company entered into an acquisition agreement to acquire 100% of the issued and outstanding shares of PGTIL. PGTIL plans to develop a biomass power plant facility. As part of the acquisition agreement, the Company is required to issue \$3,000,000 payable in shares of common stock in the event of PGTIL either purchasing the property or securing a lease permitting PGTIL to operate a biomass power plant facility. The Company is also required to issue \$33,000,000 payable in shares of common stock in the event of PGTIL securing sufficient financing for the construction of the facility.
- (c) On September 23, 2015, the Company entered into a consulting agreement with a non-related party for various services relating to marketing and promotion. Per the agreement, these services will be provided for a term of six months for consideration of \$5,000 per month and 200,000 shares of common stock of the Company due upon execution of the agreement. Refer to Note 10(h).
- (d) On November 17, 2015, PGTC entered into a commercial joint venture agreement (the “Agreement”) with a non-related party (the "Supplier") wherein the Supplier would receive and process orders, manufacture, and install products for the Company's customers. In return, the Company agreed to design the product and provide a technology license and technical support (the "Technology") to the Supplier. During the term of the Agreement, the Company will provide the Supplier with a non-transferrable right and license to use the Technology to manufacture and install the product within the Peoples’ Republic of China.

Upon receiving each order from the Company, the Supplier and the Company shall submit to each other the respective estimated budgets. For each project, after receipt of the revenue from the relevant customer, the expenses of the Company and the Supplier shall be deducted and reimbursed from the revenue proportionally. The parties have agreed to share the gross profits at an even split of 50% each.

**15. Income Taxes**

The following table reconciles the income tax benefit at the statutory rates to income tax benefit at the Company’s effective tax rate.

	2016 \$	2015 \$
Net loss before taxes	(7,446,232)	(3,053,395)
Statutory tax rate	34%	34%
Expected income tax recovery	2,531,719	1,038,154
Permanent differences and other	(1,704,462)	(398,898)
Change in enacted tax rate	-	(41,644)
Foreign tax rate difference	(101,112)	(11,867)
Change in valuation allowance	(726,145)	(585,745)
Income tax provision	<u>-</u>	<u>-</u>

**PACIFIC GREEN TECHNOLOGIES INC.**

Notes to the Consolidated Financial Statements

March 31, 2016

(Expressed in U.S. Dollars)

**15. Income Taxes (continued)**

Deferred income taxes reflect the tax effects of temporary differences between the carrying amounts of assets and liabilities for financial reporting processes. Deferred income tax assets and liabilities at March 31, 2016 and 2015 are comprised of the following:

	2016	2015
	\$	\$
Net operating losses carried forward	7,068,442	6,342,297
Valuation allowance	(7,068,442)	(6,342,297)
Net deferred tax asset	<u>—</u>	<u>—</u>

The Company has net operating losses carried forward of \$21,248,609 which may be carried forward to apply against future years' taxable income, subject to the final determination by taxation authorities, expiring in the following years:

	\$
2022	71,014
2028	7,372
2029	1,030
2030	469,466
2031	221,276
2032	248,075
2033	1,223,832
2034	14,688,151
2035	1,884,636
2036	2,433,757
	<u>21,248,609</u>

As at March 31, 2016, the Company is in arrears on filing its statutory corporate income tax returns and the amounts presented above are based on estimates. The actual losses available could differ from these estimates.

**16. Subsequent Events**

- (a) On April 30, 2016, the Company issued 246,667 shares of common stock relating to a non-brokered private placement at a price of \$1.50 per share for proceeds of \$370,000.
- (b) On May 4, 2016, the Company extended the expiry date of the stock options to purchase \$250,000 of shares of common stock at \$1.50 per share granted to an investor on June 6, 2015. The new expiry date is June 30, 2016. Refer to Note 10(e).
- (c) On May 5, 2016, the Company extended the expiry date of the stock options to purchase \$1,500,000 of shares of common stock at \$1.50 per share granted to an investor on June 6, 2015. The new expiry date is June 30, 2016. Refer to Note 10(f).
- (d) On May 19, 2016, the Company issued 150,000 shares of common stock to a director of the Company relating to a non-brokered private placement at a price of \$1.00 per share for proceeds of \$150,000, which was recorded as common stock issuable as at March 31, 2016.
- (e) On May 21, 2016, the Company issued 97,334 shares of common stock relating to a non-brokered private placement at a price of \$1.50 per share for proceeds of \$146,000.
- (f) On May 24, 2016, the Company issued 161,667 shares of common stock relating to a non-brokered private placement at a price of \$1.50 per share for proceeds of \$242,501.
- (g) On May 25, 2016 the Company entered into a tooling development agreement with a non-related party whereby the Company will pay RMB\$1,500,000 as consideration for services relating to the tooling design for the ENVI-Clean System.
- (h) On July 14, 2016, the Company issued 98,000 shares of common stock relating to a non-brokered private placement at a price of \$1.50 per share for proceeds of \$147,000.
- (i) On July 15, 2016, the Company issued 50,000 shares of common stock relating to a non-brokered private placement at a price of \$1.50 per share for proceeds of \$75,000.
- (j) On July 25, 2016, the Company received share subscription proceeds of \$300,000 for shares of common stock at a price of \$1.50 per share relating to a non-brokered private placement.
- (k) Subsequent to the year ended March 31, 2016, the Company repaid Cdn\$26,505 of an outstanding loan payable to a significant shareholder of the Company.



## Item 9A. Controls and Procedures

### *Evaluation of Disclosure Controls and Procedures*

We maintain disclosure controls and procedures, as defined in Rule 13a-15(e) promulgated under the Securities Exchange Act of 1934 (the "Exchange Act"), that are designed to ensure that information required to be disclosed by us in the reports that we file or submit under the Exchange Act is recorded, processed, summarized and reported within the time periods specified in the Securities and Exchange Commission's rules and forms and that such information is accumulated and communicated to our management, including our president (our principal executive officer, principal financial officer and principal accounting officer), as appropriate to allow timely decisions regarding required disclosure.

We carried out an evaluation, under the supervision and with the participation of our management, including our president (our principal executive officer, principal financial officer and principal accounting officer), of the effectiveness of the design and operation of our disclosure controls and procedures as of March 31, 2016. Based on the evaluation of these disclosure controls and procedures, and in light of the material weaknesses found in our internal controls over financial reporting, our president (our principal executive officer, principal financial officer and principal accounting officer) concluded that our disclosure controls and procedures were not effective.

### *Management's Report on Internal Control Over Financial Reporting*

Management is responsible for establishing and maintaining adequate internal control over financial reporting, as defined in Exchange Act Rule 13a-15(f). Our company's internal control over financial reporting is a process designed to provide reasonable assurance regarding the reliability of financial reporting and the preparation of financial statements for external purposes in accordance with accounting principles generally accepted in the United States of America.

Because of its inherent limitations, internal control over financial reporting may not prevent or detect misstatements. Also, projections of any evaluation of effectiveness to future periods are subject to the risk that controls may become inadequate because of changes in conditions, or that the degree of compliance with the policies or procedures may deteriorate.

Under the supervision and with the participation of management, including our president (our principal executive officer, principal financial officer and principal accounting officer), our company conducted an evaluation of the effectiveness of our company's internal control over financial reporting as of March 31, 2016 using the criteria established in "*Internal Control - Integrated Framework*" issued by the Committee of Sponsoring Organizations of the Treadway Commission ("COSO").

A material weakness is a deficiency, or combination of deficiencies, in internal control over financial reporting, such that there is a reasonable possibility that a material misstatement of our company's annual or interim financial statements will not be prevented or detected on a timely basis. In its assessment of the effectiveness of internal control over financial reporting as of March 31, 2016, our company determined that there were control deficiencies that constituted material weaknesses, as described below.

- *We do not have an Audit Committee* – While not being legally obligated to have an audit committee, it is the management's view that such a committee, including a financial expert member, is an utmost important entity level control over our company's financial statements. Currently the board of directors acts in the capacity of the audit committee, and does not include a member that is considered to be independent of management to provide the necessary oversight over management's activities.
- *We did not maintain appropriate cash controls* – As of March 31, 2016, our company has not maintained sufficient internal controls over financial reporting for the cash process, including failure to segregate cash handling and accounting functions, and did not require dual signature on our company's bank accounts.
- *We did not implement appropriate information technology controls* – As at March 31, 2016, our company retains copies of all financial data and material agreements; however there is no formal procedure or evidence of normal backup of our company's data or off-site storage of the data in the event of theft, misplacement, or loss due to unmitigated factors.

Accordingly, our company concluded that these control deficiencies resulted in a reasonable possibility that a material misstatement of the annual or interim financial statements will not be prevented or detected on a timely basis by our company's internal controls.

As a result of the material weaknesses described above, management has concluded that our company did not maintain effective internal control over financial reporting as of March 31, 2016 based on criteria established in Internal Control—Integrated Framework issued by COSO.

#### ***Changes in Internal Control over Financial Reporting***

There has been no change in our internal control over financial reporting identified in connection with our evaluation we conducted of the effectiveness of our internal control over financial reporting as of March 31, 2016, that occurred during our fourth fiscal quarter that has materially affected, or is reasonably likely to materially affect, our internal control over financial reporting.

This annual report does not include an attestation report of our company's registered public accounting firm regarding internal control over financial reporting. Management's report was not subject to attestation by our company's registered public accounting firm pursuant to temporary rules of the Securities and Exchange Commission that permit our company to provide only management's report in this annual report.

#### ***Continuing Remediation Efforts to address deficiencies in Company's Internal Control over Financial Reporting***

Once our company is engaged in a business of merit and has sufficient personnel available, then our board of directors, in particular and in connection with the aforementioned deficiencies, will establish the following remediation measures:

- We will attempt to increase the amount of members on our board of directors and nominate an audit committee or a financial expert in the next fiscal year, 2016- 2017.
- We will appoint additional personnel to assist with the preparation of our company's monthly financial reporting, including preparation of the monthly bank reconciliations.

#### **Item 9B. Other Information**

Effective August 31, 2013, Jordan Starkman resigned as president, treasurer, secretary and, if any, from all other offices of our company. Mr. Starkman's resignation was not the result of any disagreements with our company regarding our operations, policies, practices or otherwise. Mr. Starkman remains a director of our company.

Concurrently, on August 31, 2013, with Mr. Starkman's resignation, Neil Carmichael consented to and was appointed as president, treasurer and secretary of our company.

Effective October 1, 2013, Dr. Andrew Jolly was appointed as a director of our company.

On December 5, 2013, we appointed Mr. Chris Williams as business development director of our company. Mr. Williams subsequently resigned as business development director on April 23, 2014.



## PART III

### Item 10. Directors, Executive Officers and Corporate Governance

The following individuals serve as the directors and executive officers of our company as of the date of this annual report. All directors of our company hold office until the next annual meeting of our shareholders or until their successors have been elected and qualified. The executive officers of our company are appointed by our board of directors and hold office until their death, resignation or removal from office.

Name	Position Held with the Company	Age	Date First Elected or Appointed
Jordan Starkman	Director	45	October 26, 2008
Neil Carmichael	President, Treasurer, Secretary and Director	61	December 18, 2012
Alexander Shead	Director	55	July 20, 2015
Andrew Jolly	Director	44	October 1, 2013

#### Business Experience

The following is a brief account of the education and business experience during at least the past five years of our directors and executive officer, indicating their principal occupation during that period, and the name and principal business of the organization in which such occupation and employment were carried out.

##### *Jordan Starkman – Director*

Mr. Jordan Starkman has served as a director of our company since October 26, 2008. Mr. Starkman brings over twenty years' experience in sales, financial consulting, and investor and client relations to the Pacific Green team. He is a co-founder of Pay By the Day Company Inc. and was vice-president of operations from June 2003 prior to becoming president in January 2006. In addition to being president of Pay By The Day Company Inc., Mr. Starkman has been the president of Rimrock Gold Corp. (formerly Tucana Lithium) since August 2007 and Health Advance Inc. since April 2010, both of which are quoted on the OTCQB. Pay By The Day Company Inc. was owned by Rimrock Gold Corp. (formerly Tucana Lithium) until May 2012. Mr. Starkman spends the majority of his time overseeing the operations of Rimrock Gold Corp., a junior mining/exploration company, and Health Advance, an online medical supply company. Prior to forming Pay By The Day Company Inc. in 2003, Jordan was a sales person from January 2002 to February 2003 at The Buck A Day Company, an Ontario based direct sales company focused on sales of computers and consumer electronics, and was president of Guardians of Gold from November 2005 to October 2011. Jordan has an extensive background in finance and business development. He worked for 10 years as an independent consultant for various publicly traded companies responsible for initiating new business and developing long-term relationships with customers. Jordan also holds a BA in Statistics from the University of Western Ontario.

Mr. Starkman was appointed as our director due to his experiences in sales, financial consulting, and investor and client relations.

##### *Neil Carmichael – President, Treasurer, Secretary and Director*

Dr. Neil Carmichael was appointed as a director of our company on December 18, 2012 and as our president, treasurer and secretary on August 31, 2013. Dr. Carmichael holds a Mathematics BSc from University of Edinburgh and a Mathematics PhD from University of Warwick. Dr. Carmichael has over 25 years' energy sector management experience including international business development, strategy formulation and implementation and procurement accountabilities. From 1980-85 Dr. Carmichael worked in scientific and engineering consultancy, initially with Scicon (part of BP group) on non-linear optimization, then with Intercomp on mathematics for petroleum engineering and reservoir simulators. In 1985 he joined Shell in its reservoir engineering research unit. This was followed by positions in petroleum engineering, field development; followed by management roles in business development, personnel, information technology and procurement. This required working in a range of countries, from Peru to Bangladesh. In 2006 to 2010 he was chief executive officer of Shell Business Development Central Asia, based in Astana, Kazakhstan and responsible for Shell's new business activities in Kazakhstan, Turkmenistan and Azerbaijan. Dr. Carmichael was also the Shell representative in Turkmenistan and Azerbaijan. Since 2010 he has been working on two upstream, exploration focused, startups, one in Ukraine and the other in Pakistan. Dr. Carmichael has most recently held the position of general manager and country representative in Central Asia with Shell Exploration and Production. Dr. Carmichael has a wide range of technical, country and management experiences; mostly focused on oil and gas, much of it applicable in other domains.

### ***Alexander Shead – age 55, Director***

Alexander Shead, age 55, is a British, Australian and Swiss national. In 1993, Mr. Shead co-founded Stuart Alexander in the UK, an insurance advisory business which was sold to AXA UK. In 2004, he moved to Australia where he was a cornerstone investor and Director of Milne Alexander, a boutique insurance broking and advisory firm until its sale in 2007. Between 2007 and 2014, Mr. Shead was the Executive Chairman of the Mecon Winsure Insurance Group until its sale to Steadfast Group Limited in 2014.

In 2008, Mr. Shead founded Food Ladder International, an international NGO established to create financially sustainable social enterprises that empower disadvantaged individuals through employment. He remains a Director of Food Ladder International. In 2009, Mr. Shead became a director of First Unity Financial Group, a wealth management business that was sold in 2011. In 2012, he became and still remains as the Non-Executive Chairman of Lockton Companies Australia, the Australian arm of Lockton, the world's largest privately owned, independent insurance brokerage firm.

Mr. Shead was educated at Harrow School in England and the Sorbonne University in Paris.

### ***Andrew Jolly – Director***

Dr. Andrew Jolly was appointed as a director of our company effective October 1, 2013. Dr. Jolly is a chartered engineer, an accredited carbon trust energy adviser since 2003, a member of the Energy Institute and the Institution of Mechanical Engineers.

Through a combination of in-house technology development and implementation experience with solid, liquid and gaseous biofuels, in addition to contracted consultancy on behalf of a wide ranging client base, Dr. Jolly has honed skills in project concept generation, feasibility assessment, planning issues, economic appraisal and financing, environmental impacts and making sense of current UK environmental legislation and regulation. Consequently, he is experienced in managing the many and varied elements needed for the operational and commercial success of a renewable energy generation scheme.

Notable case studies include Wales' first dedicated 14.7 MWe wood-fired biomass combustion power plant, a 35 MWe waste wood biomass plant in Wales, two 1 MWe gasification Biomass plants and a 2 MWe AD biogas plant. Dr. Jolly has a rare 'umbrella' appreciation of the entire value chain for biomass energy projects, from forestry owner/manager right through to the supply of renewable electricity to the grid via power purchase agreements (PPA's).

Dr. Jolly is the founder of Equis Energy Limited which specializes in creating, developing and delivering concepts for generating biomass and biomass power-only projects. He has focused on the use of biomass, organic waste and hydrogen; and thus has developed a comprehensive understanding of the regulatory and legislative factors which impact the technical and commercial specification and scale of projects.

A key part of Dr. Jolly's expertise is in the assessing, accreditation and maintenance of renewable energy technologies in respect of schemes such as the renewables obligation, feed in tariffs, renewable heat incentive and combined heat and power quality assurance. These aspects of clean energy projects are crucial when the consequent benefits of such renewable energy generation schemes can comprise as much as two-thirds of the overall project income.

Dr. Jolly holds a Ph.D. in Energy Studies (1998), an MPhil in Energy Studies (1995) and a B.Eng (Hons) in Mechanical Engineering and Business Management (1993).

### **Other Directorships**

Other than as disclosed above, our directors and officer do not hold any other directorships in any company with a class of securities registered pursuant to section 12 of the Exchange Act or subject to the requirements of section 15(d) of such Act or any company registered as an investment company under the Investment Company Act of 1940.

## **Board of Directors and Director Nominees**

Since our board of directors does not include a majority of independent directors, the decisions of the board regarding director nominees are made by persons who have an interest in the outcome of the determination. The Board will consider candidates for directors proposed by security holders, although no formal procedures for submitting candidates have been adopted. Unless otherwise determined, at any time not less than 90 days prior to the next annual board meeting at which the slate of director nominees is adopted, the board will accept written submissions from proposed nominees that include the name, address and telephone number of the proposed nominee; a brief statement of the nominee's qualifications to serve as a director; and a statement as to why the security holder submitting the proposed nominee believes that the nomination would be in the best interests of our security holders. If the proposed nominee is not the same person as the security holder submitting the name of the nominee, a letter from the nominee agreeing to the submission of his or her name for consideration should be provided at the time of submission. The letter should be accompanied by a résumé supporting the nominee's qualifications to serve on the board, as well as a list of references.

The board identifies director nominees through a combination of referrals from different people, including management, existing board members and security holders. Once a candidate has been identified, the board reviews the individual's experience and background and may discuss the proposed nominee with the source of the recommendation. If the board believes it to be appropriate, board members may meet with the proposed nominee before making a final determination whether to include the proposed nominee as a member of the slate of director nominees submitted to security holders for election to the board.

Some of the factors which the board considers when evaluating proposed nominees include their knowledge of and experience in business matters, finance, capital markets and mergers and acquisitions. The board may request additional information from each candidate prior to reaching a determination. The board is under no obligation to formally respond to all recommendations, although as a matter of practice, it will endeavor to do so.

## **Conflicts of Interest**

Our directors are not obligated to commit their full time and attention to our business and, accordingly, they may encounter a conflict of interest in allocating time between our operations and those of other businesses. In the course of their other business activities, they may become aware of investment and business opportunities which may be appropriate for presentation to us as well as other entities to which they owe a fiduciary duty. As a result, they may have conflicts of interest in determining to which entity a particular business opportunity should be presented. They may also in the future become affiliated with entities, engaged in business activities similar to those we intend to conduct. In general, officers and directors of a corporation are required to present business opportunities to a corporation if:

- the corporation could financially undertake the opportunity;
- the opportunity is within the corporation's line of business; and
- it would be unfair to the corporation and its stockholders not to bring the opportunity to the attention of the corporation.

We plan to adopt a code of ethics that obligates our directors, officers and employees to disclose potential conflicts of interest and prohibits those persons from engaging in such transactions without our consent.

## **Significant Employees**

Other than as previously described, we do not expect any other individuals to make a significant contribution to our business.

## **Legal Proceedings**

To the best of our knowledge, none of our directors or executive officers has, during the past ten years:

1. been convicted in a criminal proceeding or been subject to a pending criminal proceeding (excluding traffic violations and other minor offences);
2. had any bankruptcy petition filed by or against the business or property of the person, or of any partnership, corporation or business association of which he was a general partner or executive officer, either at the time of the bankruptcy filing or within two years prior to that time;
3. been subject to any order, judgment, or decree, not subsequently reversed, suspended or vacated, of any court of competent jurisdiction or federal or state authority, permanently or temporarily enjoining, barring, suspending or otherwise limiting, his involvement in any type of business, securities, futures, commodities, investment, banking, savings and loan, or insurance activities, or to be associated with persons engaged in any such activity;
4. been found by a court of competent jurisdiction in a civil action or by the SEC or the Commodity Futures Trading Commission to have violated a federal or state securities or commodities law, and the judgment has not been reversed, suspended, or vacated;
5. been the subject of, or a party to, any federal or state judicial or administrative order, judgment, decree, or finding, not subsequently reversed, suspended or vacated (not including any settlement of a civil proceeding among private litigants), relating to an alleged violation of any federal or state securities or commodities law or regulation, any law or regulation respecting financial institutions or insurance companies including, but not limited to, a temporary or permanent injunction, order of disgorgement or restitution, civil money penalty or temporary or permanent cease-and-desist order, or removal or prohibition order, or any law or regulation prohibiting mail or wire fraud or fraud in connection with any business entity; or
6. been the subject of, or a party to, any sanction or order, not subsequently reversed, suspended or vacated, of any self-regulatory organization (as defined in Section 3(a)(26) of the Exchange Act (15 U.S.C 78c(a)(26))), any registered entity (as defined in Section 1(a)(29) of the Commodity Exchange Act (7 U.S.C. 1(a)(29))), or any equivalent exchange, association, entity or organization that has disciplinary authority over its members or persons associated with a member.

## **Audit Committee**

We do not currently have an audit committee or a committee performing similar functions. Our board of directors as a whole participates in the review of financial statements and disclosure.

## **Family Relationships**

There are no family relationships among our officers, directors, or persons nominated for such positions.

## **Compliance With Section 16(A) of the Securities Exchange Act of 1934**

Section 16(a) of the Securities Exchange Act of 1934, as amended, requires our executive officers and directors and persons who own more than 10% of a registered class of our equity securities to file with the SEC initial statements of beneficial ownership, reports of changes in ownership and annual reports concerning their ownership of our shares of common stock and other equity securities, on Forms 3, 4 and 5, respectively. Executive officers, directors and greater than 10% shareholders are required by the SEC regulations to furnish us with copies of all Section 16(a) reports they file.

Based solely on our review of the copies of such forms received by our company, or written representations from certain reporting persons that no Form 5s were required for those persons, we believe that, during the fiscal year ended March 31, 2016, all filing requirements applicable to our officers, directors and greater than 10% beneficial owners as well as our officers, directors and greater than 10% beneficial owners of our subsidiaries were complied with.

## Code of Ethics

We have adopted a Code of Business Conduct and Ethics that applies to, among other persons, members of our board of directors, our company's officers including our president, chief executive officer and chief financial officer, employees, consultants and advisors. As adopted, our Code of Business Conduct and Ethics sets forth written standards that are designed to deter wrongdoing and to promote:

1. honest and ethical conduct, including the ethical handling of actual or apparent conflicts of interest between personal and professional relationships;
2. full, fair, accurate, timely, and understandable disclosure in reports and documents that we file with, or submit to, the Securities and Exchange Commission and in other public communications made by us;
3. compliance with applicable governmental laws, rules and regulations;
4. the prompt internal reporting of violations of the Code of Business Conduct and Ethics to an appropriate person or persons identified in the Code of Business Conduct and Ethics; and
5. accountability for adherence to the Code of Business Conduct and Ethics.

Our Code of Business Conduct and Ethics requires, among other things, that all of our company's senior officers commit to timely, accurate and consistent disclosure of information; that they maintain confidential information; and that they act with honesty and integrity.

In addition, our Code of Business Conduct and Ethics emphasizes that all employees, and particularly senior officers, have a responsibility for maintaining financial integrity within our company, consistent with generally accepted accounting principles, and federal and state securities laws. Any senior officer, who becomes aware of any incidents involving financial or accounting manipulation or other irregularities, whether by witnessing the incident or being told of it, must report it to our company. Any failure to report such inappropriate or irregular conduct of others is to be treated as a severe disciplinary matter. It is against our company policy to retaliate against any individual who reports in good faith the violation or potential violation of our company's Code of Business Conduct and Ethics by another.

Our Code of Business Conduct and Ethics is attached hereto as Exhibit 14. We will provide a copy of the Code of Business Conduct and Ethics to any person without charge, upon request. Requests can be sent to: Pacific Green Technologies Inc., 5205 Prospect Road, Suite 135-226, San Jose, California, 95129.

## Item 11. Executive Compensation

The particulars of compensation paid by our company to the following persons:

- (a) our principal executive officer;
- (b) each of our two most highly compensated executive officers who were serving as executive officers at the end of the period from inception to March 31, 2016; and
- (c) up to two additional individuals for whom disclosure would have been provided under (b) but for the fact that the individual was not serving as an executive officer at the end of the period to March 31, 2016, who we will collectively refer to as our named executive officers are set out in the following summary compensation table:

**SUMMARY COMPENSATION TABLE**

Name and Principal Position	Year	Salary (\$)	Bonus (\$)	Stock Awards (\$)	Option Awards (\$)	Non-Equity Incentive Plan Compensation (\$)	Change in Pension Value and Nonqualified Deferred Compensation Earnings (\$)	All Other Compensation (\$)	Total (\$)
Jordan Starkman <sup>(1)</sup> <i>Director</i>									
	2016	Nil	Nil	Nil	Nil	Nil	Nil	Nil	Nil
	2015	Nil	Nil	Nil	Nil	Nil	Nil	Nil	Nil
Neil Carmichael <sup>(2)</sup> <i>President, Secretary, Treasurer and Director</i>									
	2016	Nil	Nil	Nil	Nil	Nil	Nil	Nil	Nil
	2015	Nil	Nil	Nil	Nil	Nil	Nil	Nil	Nil
Alexander Shead <sup>(3)</sup> <i>Director</i>									
	2016	173,862	Nil	Nil	Nil	Nil	Nil	Nil	173,862
Andrew Jolly <sup>(4)</sup> <i>Director</i>									
	2016	17,696	Nil	Nil	Nil	Nil	Nil	Nil	17,696
	2015	26,280	Nil	Nil	Nil	Nil	Nil	Nil	26,280

- (1) Jordan Starkman was appointed as president, secretary, treasurer and director of our company on November 30, 2012 and resigned as president, secretary and treasurer on August 31, 2013. Mr. Starkman remains as a member of our board of directors
- (2) Neil Carmichael was appointed as a director of our company December 18, 2012 and as president, secretary and treasurer on August 31, 2013.
- (3) Alexander Shead was appointed as a director of our company on July 20, 2015.
- (4) Andrew Jolly was appointed as a director of our company on October 1, 2013.

### Stock Option Plan

Currently, we do not have a stock option plan in favor of any director, officer, consultant or employee of our company.

### Stock Options/SAR Grants

Pursuant to the terms of the non-executive director agreement dated December 18, 2012, with Dr. Neil Carmichael, our company shall grant options to Dr. Carmichael to purchase up to 62,500 shares of common stock at an exercise price of \$0.01 per share of common stock. The options will terminate the earlier of 24 months, or upon the termination of the agreement and Dr. Carmichael's engagement with our company. As of the date of this annual report, the options to Dr. Carmichael have been granted but have not yet been exercised.

On July 20, 2015, we granted 50,000 stock options to Alexander Shead, a director of our company. The stock options are exercisable at a price of \$0.01 per share and expire on July 20, 2018.

### **Outstanding Equity Awards at Fiscal Year End**

On July 19, 2015, we granted 312,500 stock options to the President of our company. The stock options are exercisable at a price of \$0.01 per share and expire on July 19, 2018.

On July 20, 2015, we granted 50,000 stock options to Alexander Shead, a director of our company. The stock options are exercisable at a price of \$0.01 per share and expire on July 20, 2018.

On July 20, 2015, we entered into an agreement whereby a company controlled by a significant shareholder of our company can convert up to \$1,000,000 in outstanding amounts owed at a conversion rate of \$0.70 per share. The option must be exercised, if at all, during the period commencing twelve months from the date of the agreement and ending on the second anniversary of the date of the agreement.

### **Option Exercises**

During our fiscal year ended March 31, 2016, there were no options exercised by our named officers.

### **Compensation of Directors**

Effective December 18, 2012 we entered into a non-executive director agreement with Dr. Neil Carmichael, wherein Dr. Carmichael will receive compensation of \$1,000 for the term of the agreement and shall be granted options to purchase up to 62,500 shares of common stock at an exercise price of \$0.01 per share of common stock. The options will terminate the earlier of 24 months, or upon the termination of the agreement and Dr. Carmichael's engagement with our company. These options have expired.

On September 26, 2013, we entered into an agreement with Andrew Jolly, wherein Dr. Jolly agreed to serve as a director of our company. Pursuant to the agreement, our company is to compensate Dr. Jolly for serving as a director of our company at GBP2,000 (approximately \$3,235) per calendar month. Effective October 1, 2013, we appointed Dr. Jolly as a director of our company.

On October 22, 2013, we entered into an agreement with Mr. Chris Williams, wherein Mr. Williams agreed to serve as director (business development) of our company effective December 5, 2013. As business development director of our company, Mr. Williams was to focus on developing potential new business opportunities and generating sales from our existing assets. As previously stated herein, Mr. Williams resigned effective April 23, 2014 and was compensated the equivalent of \$13,918 by our company during the year ended March 31, 2014 on the basis of GBP450 (approximately \$730) per day. Mr. Williams did not receive any other incentive amounts or commissions under the agreement.

Other than the above, we do not have any agreements for compensating our directors for their services in their capacity as directors, although such directors are expected in the future to receive stock options to purchase shares of our common stock as awarded by our board of directors.

We have determined that none of our directors are independent directors, as that term is used in Item 7(d)(3)(iv)(B) of Schedule 14A under the Securities Exchange Act of 1934, as amended, and as defined by Rule 4200(a)(15) of the NASDAQ Marketplace Rules.

### **Pension, Retirement or Similar Benefit Plans**

There are no arrangements or plans in which we provide pension, retirement or similar benefits for directors or executive officers. We have no material bonus or profit sharing plans pursuant to which cash or non-cash compensation is or may be paid to our directors or executive officers, except that stock options may be granted at the discretion of the board of directors or a committee thereof.

### **Indebtedness of Directors, Senior Officers, Executive Officers and Other Management**

None of our directors or executive officers or any associate or affiliate of our company during the last two fiscal years is or has been indebted to our company by way of guarantee, support agreement, letter of credit or other similar agreement or understanding currently outstanding.

## Item 12. Security Ownership of Certain Beneficial Owners and Management and Related Stockholder Matters

The following table sets forth the ownership, as of August 12, 2016, of our common stock by each of our directors and executive officers, by all of our executive officers and directors as a group, and by each person known to us who is the beneficial owner of more than 5% of any class of our securities. As of August 12, 2016, there were 23,908,576 shares of our common stock issued and outstanding. All persons named have sole voting and investment control with respect to the shares, except as otherwise noted. The number of shares described below includes shares which the beneficial owner described has the right to acquire within 60 days of the date of this registration statement.

Name and Address of Beneficial Owner	Amount and Nature of Beneficial Ownership	Percentage of Class <sup>(1)</sup>
Jordan Starkman <sup>(2)</sup> 3651 Lindell Road Unit D155 Las Vegas NV 89103	Nil	Nil
Neil Carmichael <sup>(3)</sup> 5205 Prospect Road, Suite 135-226, San Jose, CA, 95129	40,000 <sup>(4)</sup> Common Shares	*
Andrew Jolly <sup>(5)</sup> Sophia House 28 Cathedral Road Cardiff CF11 9L1 United Kingdom	Nil Common Shares	Nil
Alexander Shead	Nil	Nil*
<b>Directors and Executive Officers as a Group</b>	<b>40,000 Common Shares</b>	<b>*0%</b>
Pacific Green Group Limited <sup>(6)</sup> Bison Court, Road Town Tortola, British Virgin Islands	1,658,396 Common Shares	7.2%
Diodati Investments Limited Palm Grove House P.O. Box 438, Road Town, Tortola, British Virgin Islands	1,440,425 Common Shares	6.2%
Salcombe Financial Limited Omar Hodge Building Wickhams Cay, 1 Road Town, Tortola, British Virgin Islands	2,105,467 Common Shares	9.1%
Fresh Air Holdings Limited Vanterpool Plaza, 2nd Floor Wickham Cay, 1 Road Town, Tortola British Virgin Islands	1,405,475 Common Shares	6.1
Intrawest Overseas Limited P.O. Box 957 Offshore Incorporations Centre Road Town Tortola, British Virgin Islands	2,622,060 Common Shares	11.3%
<b>Over 5% Shareholders</b>	<b>9,231,823 Common Shares</b>	<b>39.9%</b>

\* Less than 1%

(1) Under Rule 13d-3, a beneficial owner of a security includes any person who, directly or indirectly, through any contract, arrangement, understanding, relationship, or otherwise has or shares: (i) voting power, which includes the power to vote, or to direct the voting of shares; and (ii) investment power, which includes the power to dispose or direct the disposition of shares. Certain shares may be deemed to be beneficially owned by more than one person (if, for example, persons share the power to vote or the power to dispose of the shares). In addition, shares are deemed to be beneficially owned by a person if the person has the right to acquire the shares (for example, upon exercise of an option) within 60 days of the date as of which the information is provided. In computing the percentage ownership of any person, the amount of shares outstanding is deemed to include the amount of shares beneficially owned by such person (and only such person) by reason of these acquisition rights. As a result, the percentage of outstanding shares of any person as shown in this table does not necessarily reflect the person's actual ownership or voting power with respect to the number of shares of common stock actually outstanding on August 12, 2016. As of August 12, 2016, there were 23,908,576 shares of our company's common stock issued and outstanding.

(2) Jordan Starkman was appointed as president, secretary, treasurer and director of our company on November 30, 2012 and resigned as president, secretary and treasurer on August 31, 2013. Mr. Starkman remains as a member of our board of directors

(3) Neil Carmichael was appointed as a director of our company December 18, 2012 and as president, secretary and treasurer on August 31, 2013.

(4) Includes 40,000 common shares held indirectly by Neil Carmichael through 1728313 Ontario Ltd.

(5) Andrew Jolly was appointed as a director of our company on October 1, 2013.

(6) Scott Poulter has voting and dispositive control over shares owned by Pacific Green Group Limited.





## Changes in Control

We are unaware of any contract or other arrangement or provisions of our Articles or Bylaws the operation of which may at a subsequent date result in a change of control of our company.

### Item 13. Certain Relationships and Related Transactions, and Director Independence

Other than set forth below, there have been no other transactions since the beginning of our last fiscal year or any currently proposed transactions in which we are, or plan to be, a participant and the amount involved exceeds \$120,000 or one percent of the average of our total assets at year end for the last two completed fiscal years, and in which any related person had or will have a direct or indirect material interest.

During the years ended March 31, 2016 and 2015, \$1,617,299 and \$276,679 of consultancy fees were incurred with respect to the officers, directors and companies controlled by them, respectively.

On October 27, 2015, our company entered into a loan agreement with a significant shareholder for proceeds of approximately \$4,231. The loan is unsecured, bears an interest rate of US Prime Rate plus 4%, and is due on demand.

As at March 31, 2016 and March 31, 2015, we had amount due to/from related parties as follows:

<b>Due to (from) related parties</b>	<b>March 31, 2016</b>		<b>March 31, 2015</b>	
	<b>Due from related parties<sup>(2)</sup></b>	<b>Due to related parties<sup>(2)</sup></b>	<b>Due from related parties<sup>(2)</sup></b>	<b>Due to related parties<sup>(2)</sup></b>
	\$	\$	\$	\$
PGG <sup>(1)</sup>	Nil	4,862,555	Nil	4,937,037
EnviroTechnologies <sup>(1)</sup>	Nil	Nil	Nil	29,762
Pacific Green Development Ltd.	38,506	Nil	Nil	98,389
Other shareholders	984	38,430	Nil	818
Other directors	11,257	124,264	11,257	Nil
Total	<u>50,747</u>	<u>5,025,249</u>	<u>11,257</u>	<u>5,066,006</u>

(1) Both Sichel Limited, Pacific Green Development Ltd. and PGG are wholly owned subsidiaries of the Hookipia Trust. Sichel is a shareholder of our company, and provides consulting services pursuant to a consulting agreement dated May 1, 2010. The sole director of Sichel is also the sole director of PGG.

(2) The loan is unsecured, non-interest bearing, and is due on demand.

Related party transactions occurred in the normal course of operations on terms and conditions that are similar to those of transactions with unrelated parties and, therefore, are measured at the exchange amount.

## Director Independence

We currently act with three directors, Mr. Jordan Starkman, Dr. Neil Carmichael and Dr. Andrew Jolly. None of our directors qualify as “independent directors” as defined by Nasdaq Marketplace Rule 4200(a)(15).

We do not have standing audit, compensation or nominating committees; our directors act in those capacities. We believe that our directors are capable of analyzing and evaluating our financial statements and understanding internal controls and procedures for financial reporting. To the extent that our directors are not capable of effectively performing those tasks, our directors intend to seek appropriate professional guidance. The board of directors of our company does not believe that it is necessary, given our early stage of development, to have a standing audit, compensation or nominating committees because we believe that the functions of such committees can be adequately performed by the board of directors. Additionally, we believe that retaining an independent director who would qualify as an “audit committee financial expert” would be overly costly and burdensome and is not warranted in our circumstances given the early stages of our development.

## Item 14. Principal Accounting Fees and Services

The aggregate fees billed for the most recently completed fiscal year ended March 31, 2016 and for fiscal year ended March 31, 2015 for professional services rendered by the principal accountant for the audit of our annual financial statements and review of the financial statements included in our quarterly reports on Form 10-Q and services that are normally provided by the accountant in connection with statutory and regulatory filings or engagements for these fiscal periods were as follows:

	Year Ended	
	March 31, 2016	March 31, 2015
	\$	\$
Audit Fees	\$ 17,000	\$ 19,500
Audit Related Fees	15,200	13,600
Tax Fees	-	-
All Other Fees	-	-
Total	<u>32,200</u>	<u>33,100</u>

Our board of directors pre-approves all services provided by our independent auditors. All of the above services and fees were reviewed and approved by the board of directors either before or after the respective services were rendered.

Our board of directors has considered the nature and amount of fees billed by our independent auditors and believes that the provision of services for activities unrelated to the audit is compatible with maintaining our independent auditors' independence.

## PART IV

### Item 15. Exhibits, Financial Statement Schedules

#### (a) Financial Statements

1. Financial statements for our company are listed in the index under Item 8 of this document.
2. All financial statement schedules are omitted because they are not applicable, not material or the required information is shown in the financial statements or notes thereto.

#### (b) Exhibits

<b>Exhibit Number</b>	<b>Description</b>
<b>(2)</b>	<b>Plan of Acquisition, Reorganization, Arrangement Liquidation or Succession</b>
2.1	Assignment and Share Transfer Agreement dated June 14, 2012 between our company, Pacific Green Technologies Limited and Pacific Green Group Limited (incorporated by reference to our Registration Statement on Form 10, filed on July 3, 2012)
<b>(3)</b>	<b>Articles of Incorporation and Bylaws</b>
3.1	Articles of Incorporation filed on July 3, 2012 (incorporated by reference to our Registration Statement on Form 10, filed on July 3, 2012)
3.2	Certificate of Amendment filed on August 15, 1995 (incorporated by reference to our Registration Statement on Form 10, filed on July 3, 2012)
3.3	Certificate of Amendment filed on August 5, 1998 (incorporated by reference to our Registration Statement on Form 10, filed on July 3, 2012)
3.4	Certificate of Amendment filed on October 15, 2002 (incorporated by reference to our Registration Statement on Form 10, filed on July 3, 2012)
3.5	Certificate of Amendment filed on May 8, 2006 (incorporated by reference to our Registration Statement on Form 10, filed on July 3, 2012)
3.6	Certificate of Amendment filed on May 29, 2012 (incorporated by reference to our Registration Statement on Form 10, filed on July 3, 2012)
3.7	Bylaws filed on July 3, 2012 (incorporated by reference to our Registration Statement on Form 10, filed on July 3, 2012)
3.8	Certificate of Amendment filed on November 30, 2012 (incorporated by reference to our Current Report on Form 8-K filed on December 11, 2012)
<b>(4)</b>	<b>Instruments Defining the Rights of Security Holders, Including Indentures</b>
4.1	Share Certificate relating to shares held by our company in the Ordinary Share Capital of Peterborough Renewable Energy Limited (incorporated by reference to our Current Report on Form 8-K filed on December 12, 2013)
<b>(10)</b>	<b>Material Contracts</b>
10.1	Consulting Agreement dated May 1, 2010 between our company and Sichel Limited (incorporated by reference to our Registration Statement on Form 10, filed on July 3, 2012)
10.2	Representation Agreement dated June 7, 2010 between Pacific Green Group Limited and EnviroTechnologies, Inc. (incorporated by reference to our Registration Statement on Form 10, filed on July 3, 2012)
10.3	Peterborough Agreement dated October 5, 2011 between EnviroResolutions, Inc., Peterborough Renewable Energy Limited and Green Energy Parks Limited (incorporated by reference to our Registration Statement on Form 10, filed on July 3, 2012)
10.4	Promissory Note dated June 2012 between our company and Pacific Green Group Limited (incorporated by reference to our Registration Statement on Form 10, filed on July 3, 2012)
10.5	Assignment and Share Transfer Agreement dated June 14, 2012 between our company, Pacific Green Technologies Limited and Pacific Green Group Limited (incorporated by reference to our Registration Statement on Form 10, filed on July 3, 2012)
10.6	Non-Executive Director Agreement dated December 18, 2012 between our company and Neil Carmichael (incorporated by reference to our Current Report on Form 8-K filed on December 19, 2012)
10.7	Supplemental Agreement dated March 5, 2013 between EnviroResolutions, Inc., Peterborough Renewable Energy Limited and Green Energy Parks Limited (incorporated by reference to our Annual Report on Form 10-K filed on July 1, 2013)
10.8	Supplemental Agreement dated March 5, 2013 between our company, EnviroTechnologies Inc. and EnviroResolutions Inc. (incorporated by reference to our Current Report on Form 8-K filed on March 13, 2013)
10.9	Form of Share Exchange Agreement dated April 3, 2013 between our company and Shareholders of EnviroTechnologies Inc. (incorporated by reference to our Current Report on Form 8-K filed on April 8, 2013)
10.10	Form of Share Exchange Agreement dated April 25, 2013 between our company and Shareholders of EnviroTechnologies Inc. (incorporated by reference to our Current Report on Form 8-K filed on April 30, 2013)
10.11	Stock Purchase Agreement dated May 16, 2013 between our company and Shareholders of Pacific Green Energy Parks (incorporated by reference to our Current Report on Form 8-K/A filed on June 3, 2013)
10.12	Debt Settlement Agreement dated May 17, 2013 between our company, EnviroResolutions, Inc. and EnviroTechnologies, Inc. (incorporated by reference to our Current Report on Form 8-K/A filed on June 3, 2013)
10.13	Form of Share Exchange Agreement between our company and Shareholders of EnviroTechnologies, Inc. (incorporated by reference to our Current Report on Form 8-K filed on August 9, 2013)
10.14	Form of Share Exchange Agreement between our company and Shareholders of EnviroTechnologies, Inc. (incorporated by reference to our Current Report on Form 8-K filed on August 30, 2013)
10.15	Agreement dated September 26, 2013 between our company and Andrew Jolly (incorporated by reference to our Current Report on Form 8-K filed on October 3, 2013)



<b>Exhibit Number</b>	<b>Description</b>
10.16	Form of Share Exchange Agreement between our company and Shareholders of EnviroTechnologies, Inc. (incorporated by reference to our Current Report on Form 8-K filed on October 22, 2013)
10.17	Agreement dated October 22, 2013 between our company and Chris Williams (incorporated by reference to our Current Report on Form 8-K filed on December 5, 2013)
10.18	Form of Subscription Agreement between our company and the subscribers (incorporated by reference to our Current Report on Form 8-K filed on December 24, 2013)
10.19	Form of Share Exchange Agreement between our company and certain shareholders of EnviroTechnologies, Inc. (incorporated by reference to our Current Report on Form 8-K filed on December 27, 2013)
10.20	Agreement dated January 27, 2014 between our company and Pöyry Management Consulting (UK) Limited (incorporated by reference to our Quarterly Report filed on Form 10-Q on February 19, 2014)
10.21	Form of Subscription Agreement between our company and the subscribers (incorporated by reference to our Current Report on Form 8-K filed on March 11, 2014)
10.22	Agreement between our company and Alexander Shead dated July 20, 2015 (incorporated by reference to our Current Report on Form 8-K filed on July 30, 2015).
10.23	Investor Relations Agreement dated September 22, 2015 between Pacific Green Technologies Inc. and Midam Ventures, LLC (incorporated by reference to our Current Report on Form 8-K filed on December 8, 2015).
10.24	Investor Relations Agreement dated October 24, 2015 between Pacific Green Technologies Inc. and Red Rock Marketing Media, Inc. (incorporated by reference to our Current Report on Form 8-K filed on December 21, 2015).
10.25	Commercial Joint Venture Agreement between PowerChina SPEM Company Limited and Pacific Green Technologies China Limited dated November 17, 2015 (incorporated by reference to our Current Report on Form 8-K filed on December 21, 2015).
<b>(14)</b>	<b>Code of Ethics</b>
14.1	Code of Ethics and Business Conduct (incorporated by reference to our Current Report on Form 10-K filed on July 16, 2015).
<b>(21)</b>	<b>Subsidiaries of the Registrant</b>
21.1	Pacific Green Technologies Limited, a United Kingdom corporation (wholly owned); Pacific Green Energy Parks Limited, a British Virgin Islands corporation (wholly owned); Energy Park Sutton Bridge, a United Kingdom corporation (wholly owned by Pacific Green Energy Parks Limited).
<b>(31)</b>	<b>Rule 13a-14 (d)/15d-14d) Certifications</b>
31.1*	Section 302 Certification by the Principal Executive Officer, Principal Financial Officer and Principal Accounting Officer
<b>(32)</b>	<b>Section 1350 Certifications</b>
32.1*	Section 906 Certification by the Principal Executive Officer, Principal Financial Officer and Principal Accounting Officer
<b>(99)</b>	<b>Additional Exhibits</b>
99.1	Peterborough Renewable Energy Limited Directors' Report and Financial Statements for the period ended December 31, 2012 (incorporated by reference to our Current Report on Form 8-K filed on December 12, 2013)
<b>101*</b>	<b>Interactive Data Files</b>
101.INS	XBRL Instance Document
101.SCH	XBRL Taxonomy Extension Schema Document
101.CAL	XBRL Taxonomy Extension Calculation Linkbase Document
101.DEF	XBRL Taxonomy Extension Definition Linkbase Document
101.LAB	XBRL Taxonomy Extension Label Linkbase Document
101.PRE	XBRL Taxonomy Extension Presentation Linkbase Document

\* Filed herewith.

## SIGNATURES

In accordance with Section 13 or 15(d) of the Exchange Act, the registrant caused this report to be signed on its behalf by the undersigned, thereunto duly authorized.

**PACIFIC GREEN TECHNOLOGIES INC.**  
(Registrant)

Dated: : September 8, 2016

By: /s/ Neil Carmichael  
**Neil Carmichael**  
President, Secretary, Treasurer and Director  
(Principal Executive Officer,  
Principal Financial Officer and  
Principal Accounting Officer)

Pursuant to the requirements of the Securities Exchange Act of 1934, this report has been signed below by the following persons on behalf of the registrant and in the capacities and on the dates indicated.

Dated: : September 8, 2016

By: /s/ Neil Carmichael  
**Neil Carmichael**  
President, Secretary, Treasurer and Director  
(Principal Executive Officer,  
Principal Financial Officer and  
Principal Accounting Officer)

Dated: : September 8, 2016

By: /s/ Jordan Starkman  
**Jordan Starkman**  
Director

Dated: : September 8, 2016

By: /s/ Andrew Jolly  
**Andrew Jolly**  
Director

**CERTIFICATION PURSUANT TO  
18 U.S.C. ss 1350, AS ADOPTED PURSUANT TO  
SECTION 302 OF THE SARBANES-OXLEY ACT OF 2002**

I, Neil Carmichael, certify that:

1. I have reviewed this annual report on Form 10-K/ of Pacific Green Technologies Inc. for the year ended March 31, 2016;
2. Based on my knowledge, this report does not contain any untrue statement of a material fact or omit to state a material fact necessary to make the statements made, in light of the circumstances under which such statements were made, not misleading with respect to the period covered by this report;
3. Based on my knowledge, the financial statements, and other financial information included in this report, fairly present in all material respects the financial condition, results of operations and cash flows of the registrant as of, and for, the periods presented in this report;
4. The registrant's other certifying officer(s) and I are responsible for establishing and maintaining disclosure controls and procedures (as defined in Exchange Act Rules 13a-15(e) and 15d-15(e)) and internal control over financial reporting (as defined in Exchange Act Rules 13a-15(f) and 15d-15(f)) for the registrant and have:
  - (a) Designed such disclosure controls and procedures, or caused such disclosure controls and procedures to be designed under our supervision, to ensure that material information relating to the registrant, including its consolidated subsidiaries, is made known to us by others within those entities, particularly during the period in which this report is being prepared;
  - (b) Designed such internal control over financial reporting, or caused such internal control over financial reporting to be designed under our supervision, to provide reasonable assurance regarding the reliability of financial reporting and the preparation of financial statements for external purposes in accordance with generally accepted accounting principles;
  - (c) Evaluated the effectiveness of the registrant's disclosure controls and procedures and presented in this report our conclusions about the effectiveness of the disclosure controls and procedures, as of the end of the period covered by this report based on such evaluation; and
  - (d) Disclosed in this report any change in the registrant's internal control over financial reporting that occurred during the registrant's most recent fiscal quarter (the registrant's fourth fiscal quarter in the case of an annual report) that has materially affected, or is reasonably likely to materially affect, the registrant's internal control over financial reporting; and
5. The registrant's other certifying officer(s) and I have disclosed, based on our most recent evaluation of internal control over financial reporting, to the registrant's auditors and the audit committee of the registrant's board of directors (or persons performing the equivalent functions):
  - (a) All significant deficiencies and material weaknesses in the design or operation of internal control over financial reporting which are reasonably likely to adversely affect the registrant's ability to record, process, summarize and report financial information; and
  - (b) Any fraud, whether or not material, that involves management or other employees who have a significant role in the registrant's internal control over financial reporting.

Date: September 8, 2016

/s/ Neil Carmichael

Neil Carmichael  
President, Secretary, Treasurer and Director  
(Principal Executive Officer,  
Principal Financial Officer and  
Principal Accounting Officer)  
Pacific Green Technologies Inc.



**CERTIFICATION PURSUANT TO  
18 U.S.C. SECTION 1350, AS ADOPTED PURSUANT TO  
SECTION 906 OF THE SARBANES-OXLEY ACT OF 2002**

I, Neil Carmichael, hereby certify, pursuant to 18 U.S.C. Section 1350, as adopted pursuant to Section 906 of the Sarbanes-Oxley Act of 2002, that:

- (1) the Annual Report on Form 10-K of Pacific Green Technologies Inc. for the period ended March 31, 2016 (the "**Report**") fully complies with the requirements of Section 13(a) or 15(d) of the Securities Exchange Act of 1934; and
- (2) the information contained in the Report fairly presents, in all material respects, the financial condition and results of operations of Pacific Green Technologies Inc.

Dated: September 8, 2016

*/s/ Neil Carmichael*

---

Neil Carmichael  
President, Secretary, Treasurer and Director  
(Principal Executive Officer,  
Principal Financial Officer and  
Principal Accounting Officer)  
Pacific Green Technologies Inc.

A signed original of this written statement required by Section 906, or other document authenticating, acknowledging, or otherwise adopting the signature that appears in typed form within the electronic version of this written statement required by Section 906, has been provided to Pacific Green Technologies Inc. and will be retained by Pacific Green Technologies Inc. and furnished to the Securities and Exchange Commission or its staff upon request.